

Eddystone

**MODEL 40A
BOOK 1**

OPERATORS HANDBOOK

Eddystone Radio Limited

Member of Marconi Communication Systems Limited

Alvechurch Road, Birmingham B31 3PP, England

Telephone: 021-475 2231

Cables: Eddystone Birmingham Telex: 337081



FIRST AID IN CASE OF ELECTRIC SHOCK

The Royal Life Saving Society recommends the Expired Air method of artificial respiration for use in any case of electric shock. It is comparatively simple and produces the best and quickest results when correctly applied. It also has an important advantage over the accepted manual methods in that it can be carried out in awkward situations in confined spaces, such as might well be encountered at sea.

However, where there is a facial injury, or if the patient is trapped in a face downwards position, it might be necessary to use a manual method of artificial respiration: of this type the Holger Nielson method is considered the most satisfactory

Directions for applying both methods are therefore given.

EXPIRED AIR METHOD OF ARTIFICIAL RESPIRATION

It is essential to commence artificial respiration without delay.

DO NOT TOUCH THE VICTIM WITH YOUR BARE HANDS until the circuit is broken.

SWITCH OFF. If this is not possible, **PROTECT YOURSELF** with dry insulating material and pull the victim clear of the conductor.

1. Lay the patient on his back and, if on a slope, have the stomach slightly lower than the chest.
2. Make a brief inspection of the mouth and throat to ensure that they are clear of obvious obstruction.
3. Give the patient's head the maximum backwards tilt so that the chin is prominent, the mouth closed and the neck stretched to give a clear airway—Fig. A.
4. Open your mouth wide, make an airtight seal over the nose of the patient and blow. The operator's cheek or the hand supporting the chin can be used to seal the patient's lips—Fig. B, or if the nose is blocked, open the patient's mouth using the hand supporting the chin; open your mouth wide and make an airtight seal over his mouth and blow—Fig. C. This may also be used as an alternative to the mouth-to-nose technique.
5. After exhaling, turn your head to watch for chest movement whilst inhaling deeply in readiness for blowing again—Fig. D.
6. If the chest does not rise, check that the patient's mouth and throat are free of obstruction and the head is tilted backwards as far as possible. Blow again.

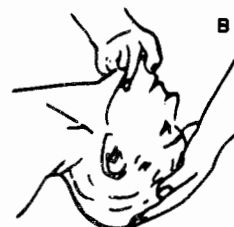

Send for medical assistance if possible.

HOLGER NIELSON METHOD OF ARTIFICIAL RESPIRATION

It is essential to commence artificial respiration without delay.

DO NOT TOUCH THE VICTIM WITH YOUR BARE HANDS until the circuit is broken.

SWITCH OFF. If this is not possible, **PROTECT YOURSELF** with dry insulating material and pull the victim clear of the conductor.

1. **Lay patient face downwards** with the forehead resting on the hands, placed one above the other.



2. **Remove false teeth, tobacco or gum** from patient's mouth; make sure the **tongue is free** by firm blows between the shoulders with the flat of the hand.

3. **Kneel on one knee at patient's head**, one foot by the patient's elbow.

4. **Place palms of your hands on patient's shoulder blades**—Fig. A.



5. **Rock forward until arms are vertical**, the pressure should be light and without force (22-30 lb. is sufficient); this should take $2\frac{1}{2}$ seconds—Fig. B.

6. **Release the pressure** by allowing the hands to slide down the arms to the patient's elbow (approximately 1 second) then raise the patient's arms and shoulders slightly pulling at the same time by swinging backwards (approximately $2\frac{1}{2}$ seconds)—Fig. C. lower the patient's arms—Fig. D, and return your hands to the patient's shoulder blades.

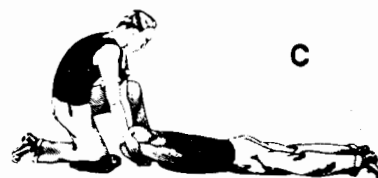

7. **Repeat the movements** taking 7 seconds for each complete respiration.

8. **While artificial respiration is continued, have someone else—**

(a) Loosen patient's clothing.

(b) Keep patient warm.

9. **If patient stops breathing, continue artificial respiration.** Four hours or more may be required.



10. **Do not give liquids until patient is conscious.**

Send for medical assistance if possible.

HEALTH & SAFETY AT WORK ACT 1974 (UNITED KINGDOM)

The objective of this Act is to maintain or improve standards of health, safety and welfare of persons at work, and to protect persons at work and others, against risks to health, safety and welfare.

To the best of current knowledge, there is no risk to health or safety when Eddystone equipment is installed and operated properly, provided it has been properly maintained.

Precautions have been taken during the design and manufacture of this equipment to reduce the risks involved when repairing or maintaining the equipment but a certain degree of risk must always be present, particularly under fault conditions. The list below has been prepared to draw attention to the general risks envisaged; further information is available from Eddystone Radio Limited, at any time.

1. **Electric Shock**

Beware mains voltage and induced aerial voltages, ensure metal chassis is properly bonded to earth. Some units generate a high voltage even when the equipment is operated from a battery supply. Circuitry operating at low voltage is not necessarily at or near earth potential.

2. **Physical Strain**

Obtain assistance if a heavy unit is to be lifted or removed from an equipment rack.

3. **Explosion and Implosion**

Cathode ray tubes may implode if carelessly handled or dropped.

Use protective masks and gloves.

Electrolytic capacitors may explode if subjected to excessive voltage or voltage of incorrect polarity, and toxic materials may be released.

4. **Burns**

Resistors and power transistors (for example) may attain a high temperature. Avoid contact with these.

5. **X-Rays**

Cathode ray tubes operated at excessive voltage may generate harmful X-rays.

6. **Soldering**

Beware of flying droplets of molten solder and careless use of soldering irons (place in a proper stand when not in use). Avoid fumes. Do not handle food or drink, cigarettes, etc., without washing hands (risk from lead poisoning).

7. **Cleaning Solutions**

Certain solutions give off flammable or toxic fumes, e.g., trichloroethylene and its derivatives. Do not smoke and avoid inhalation of vapours.

8. **Disposal of Faulty Components**

Certain components contain toxic materials which may be released if the component is broken or disposed of carelessly, e.g., semi conductor devices containing poisonous metallic compounds; electrolytic capacitors containing poisonous organic compounds.

TREATMENT FOR BURNS

1. No attempt should be made to remove clothing adhering to the burn.
2. If other help is available, or as soon as artificial respiration is no longer required, cover the burn with a **dry** dressing.
3. Oil or grease in any form should **not** be applied.
4. Warm, weak, sweet tea may be given when the patient is able to swallow.

These instructions are approved by The Royal Life Saving Society. A handbook and charts dealing with Artificial Respiration can be obtained from the Society at 14 Devonshire Street, London, W.1.

NOTE : : AC MAINS CONNECTOR

The following information is issued in compliance with British Standard BS415:-

If the colours of the wires in the mains lead of this apparatus do not correspond with the coloured markings identifying the terminals in your mains connector (or plug) proceed as follows:-

1. The GREEN/YELLOW wire must be connected to the plug terminal marked "E" or "  " or coloured GREEN or GREEN/YELLOW.
2. The BLUE wire must be connected to the plug terminal marked "N" or coloured either BLUE or BLACK.
3. The BROWN wire must be connected to the plug terminal marked "L" or coloured either BROWN or RED.
4. If a 13 amp (BS1363) FUSED PLUG is used to facilitate connection to the supply outlet, the plug MUST be protected by a 3 AMP FUSE unless expressly declared otherwise (see para. 5 below). If another type of plug is used, a fuse of the appropriate rating must be fitted either in the plug, or the adaptor, OR AT THE DISTRIBUTION BOARD.
5. NOTE:

A 3 AMP fuse rating is sufficient for most equipments, but in some instances, to allow for switching surges, it may be necessary to use a 5 AMP FUSE RATING. In all instances where the higher rating is applicable, specific notice will be given in the INSTALLATION SECTION of the handbook at the POWER SUPPLIES subsection.

Eddystone

NOISE MEASURING SET

MODEL 40A

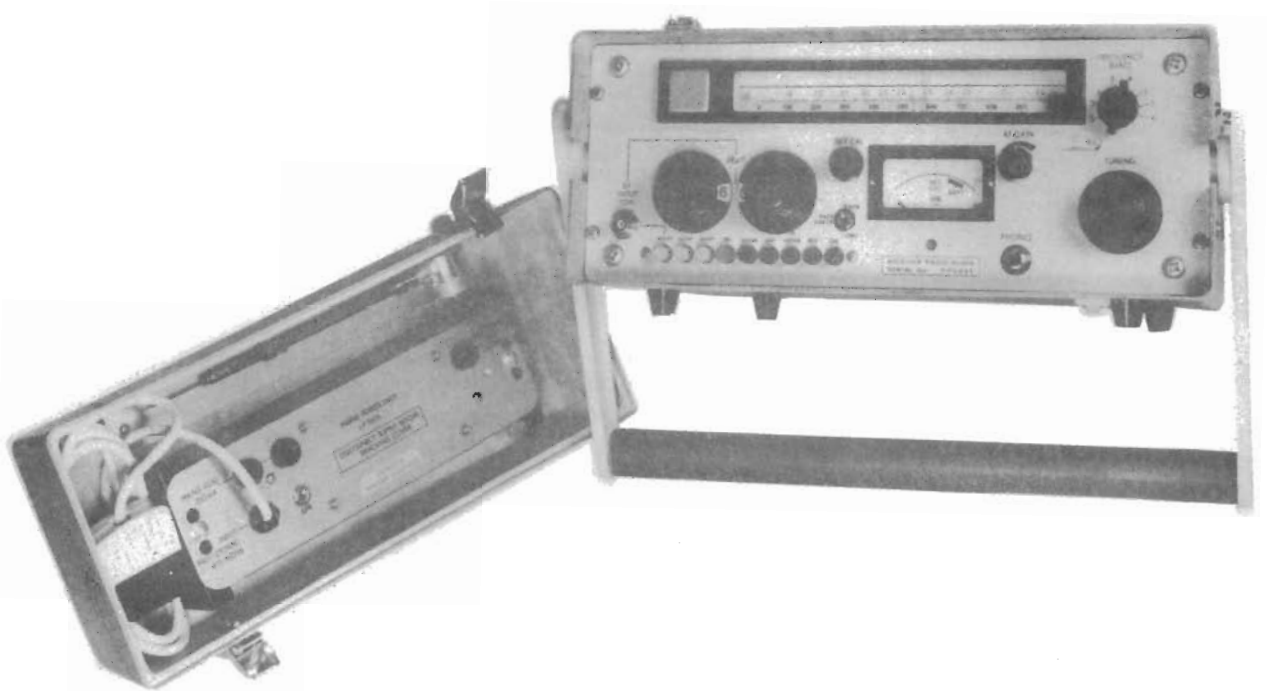

Manufactured in England by



EDDYSTONE RADIO LIMITED

MEMBER OF MARCONI COMMUNICATION SYSTEMS LIMITED
ALVECHURCH ROAD, BIRMINGHAM B31 3PP

Telephone: 021-475 2231

Telex: 337081



AMENDMENT RECORD

Amend No.	Pages subject to change	Amended by	Date
1			
2			
3			
4			
5			
6			
7			
8			
9			
10			
11			
12			
13			
14			
15			
16			
17			
18			
19			
20			
21			
22			
23			
24			
25			
26			
27			
28			
29			
30			

The Manufacturer reserves the right to modify the content of this publication as necessary to accommodate modifications, design improvements etc. Relevant Amendment Sheets will be incorporated at date of issue.

CONTENTS

Section 1	INTRODUCTION	Page 1-1
	TECHNICAL DATA SUMMARY	Page 1-3

Section 2	COMMISSIONING NOTES (Installation)	Page 2-1
	POWER SUPPLIES (MAINS VOLTAGE ADJUSTMENT)	Page 2-3

ILLUSTRATIONS :-

Fig 1	IF OUTPUT SOCKET AND ANCILLARY CONNECTIONS	Page 2-2
	PCB LINK ARRANGEMENT (Power Supply) FOR)	
	MAINS VOLTAGE SETTINGS)	Page 2-4

NOTE : : Refer to BOOK 2 for all technical data and Circuit Diagrams.

INTRODUCTION

General

Book 1

This handbook provides the detailed commissioning notes and comprehensive operating instructions required for Radio Receiver type 40A (British Home Office design) manufactured by Eddystone Radio Limited.

It is important to note that Book 2, which is a separate publication, provides the overall technical information and service data. It is therefore essential to refer to Book 2 whenever detailed modification data or maintenance instruction is required.

Guarantee

All 40A Series receivers are suitable for continuous use under normal operating conditions and should require very little routine maintenance over long periods of operation. With the exception of the semi-conductor devices, all components are guaranteed by the Manufacturer for a period of one year from the date of purchase. The semi-conductor devices are covered by a separate guarantee.

Servicing

Spares for user servicing can be supplied and advice will be freely given when required. Any enquiries relating to service matters should be directed to the "Sales and Service Department", Eddystone Radio Limited, at our usual address. Please quote the equipment Model number and Serial number in all communications. Should major servicing become necessary the unit can, by prior arrangement, be returned to the Manufacturer for attention; care should be taken to ensure that the unit is well protected against possible damage during transit.

General Description

Radio Receiver type 40A, is a portable Radio Frequency Interference (RFI) measuring set, designed to meet the special requirements of the British Post Office and, in general, the special requirements of the specification set down in CISPR (16). The equipment is primarily intended for use by personnel engaged in the investigation of RFI in the frequency range 130kHz to 32MHz. The receiver is also ideally suited to many industrial uses, including acceptance testing on a wide range of electrical appliances.

Measurements can be taken of the voltage or field strength of CW signals, or impulsive noise with pulse repetition frequencies as low as 1Hz. Integral ferrite loop aerials or the "whip" aerial supplied, are utilized for interference tracing. Separate correction and conversion tables are supplied with calibrated aerials specifically intended for field strength measurements or radiated noise measurements, or to facilitate the assessment of conducted noise using a suitable artificial mains network.

The equipment is extremely simple to operate and long term accuracy of a high order is assured by standardising the overall system gain against an internal impulse calibrator, prior to taking each reading. Power is derived from a self-contained battery supply (type LP3627) utilizing six International Type D dry cells ("U2" or equivalent) for field operation.

Alternatively, a standard AC source in the range 105-125/190-270V 40-60Hz can be used via the mains power supply module (type LP3618) supplied.

The receiver takes the form of a conventional single superhet with an intermediate frequency of 1.75MHz. As such it has an input impedance of 50Ω and is fed via the front panel "RF INPUT 50Ω " socket and the 10dB and 1dB step attenuators. When either 'LOOP' or 'WHIP' aerials are selected, they are switched (internally) to this input via an additional impedance converting aerial amplifier. For gain standardisation (Calibration) the fixed level output of the internal broadband impulse generator is also switched to this input, though in this case by-passing the attenuators. The output meter is fed from the amplified output of the quasi-peak rectifier. A high impedance DC output direct from the detector is provided on the rear ancillary connector. Other facilities include AGC and a +20dB gain setting, both which operate on the IF amplifier. The AGC line is brought out to the rear ancillary connector to enable the connection of additional AGC time constant capacitors. A buffered pre-detector output from the IF amplifier is brought out to the rear panel BNC connector. The receiver can also be operated from an external DC supply via an input on the rear ancillary connector. This input is diode protected to prevent accidental polarity reversal of the supply from causing damage - however the internal power supply must be disconnected when an external power supply is used. (See Commissioning Notes).

The extendable whip aerial is supplied in the cabinet lid and must be fitted to the UHF - type input socket located beneath the protection cover on the RH side of the cabinet (See Commissioning Notes), when 'WHIP' is selected.

For audio monitoring an envelope detector is provided with an audio amplifier supplying an internal monitor speaker and the 'PHONES' jack socket on the front panel. When a plug is inserted in this socket, the internal loudspeaker is automatically muted.

TECHNICAL DATA SUMMARY

Input impedance	:	$50\Omega \pm 10\%$ at the tuned frequency with 10dB or more attenuation being used.
Measurement range	:	(equivalent sinewave p. d. input) $0\text{dB}\mu\text{V}$ to $100\text{dB}\mu\text{V}$ with use of 'IF +20dB' facility. An extra + 5dB range at any point is obtainable using the meter, but with a slight reduction in accuracy (0.5dB).
Detector output	:	$\geq +150\text{mV}$ D.C. at 'SET CAL' reading on meter (output across $10\text{M}\Omega$ load). Output is proportional to quasi-peak rectifier output voltage.
IF Output	:	$\geq 50\text{mV}$ p. to p. emf with a sinewave input giving 'SET CAL' on meter.
IF Frequency	:	1.75MHz.
External power supply input	:	+8.0 to +10.5V DC for optimum operation (n.b. this input is diode protected against accidental reversal of polarity).
Weight	:	= 10kg total package (approx).
Dimensions	:	WIDTH : 385mm including handle. HEIGHT : 161mm including feet. DEPTH : 358mm including feet.
Bandwidth	:	9kHz \pm 1kHz.
Bandwidth at 60dB	:	36kHz maximum.
Electrical charge time constant of rectifier circuit	:	approx 1mS.
Electrical discharge time constant of rectifier circuit	:	approx 160mS.
Mechanical time constant of critically damped meter (to 35% of steady deflection)	:	approx 160mS.
IF and image rejection (150kHz - 30MHz)	:	better than 40dB.
Spurious response rejection	:	better than 40dB.
Accuracy of sinewave voltage measurement	:	Within $\pm 2\text{dB}$ (at 'SET CAL' mark on meter).

Screening	:	With the receiver in a RF field 80dB μ V/M in frequency range 130kHz - 32MHz, the indication on the meter shall not exceed 'SET CAL' after calibration.
Internal noise	:	Does not exceed -5dB point on meter after calibration.
Pulse response ('CISPR' selected).	:	Between 150kHz and 30MHz after calibration.

n.b. When 'LONG' is selected the variation in response at low prfs is widened by a few dB.

PRF (Hz)	Relative equivalent level of pulse for 'SET CAL' on meter (dB).
1000	-4.5 \pm 1.0
100 (ref)	0 (ZERO)
20	+6.5 \pm 1.0
10	+ 10 \pm 1.5
2	+20.5 \pm 2.0
1	+22.5 \pm 2.0
Isolated pulse	+23.5 + 2.0/ -3.0

Frequency calibration	:	Within \pm 2%.
Audio Output	:	At least 100mW into an 8 Ω load at the front panel phone jack.
Environmental	:	Equipment meets DEF 135 for category III equipment. Operating temperature - range -5 $^{\circ}$ C to +55 $^{\circ}$ C RH not exceeding 30% and 0 $^{\circ}$ C to 40 $^{\circ}$ C, RH not less than 95% at +40 $^{\circ}$ C.

Section 2

COMMISSIONING NOTES

- A) The receiver is generally supplied as follows:
- (1) Radio Receiver type 40A fitted in glass-fibre cabinet.
 - (2) Battery supply module type LP3627 (for use with 6 x International Type D dry cells).
 - (3) Removable cabinet lid which is also utilized for storing the Mains power supply module type LP3618.
 - (4) Extending "whip" aerial type LP3628 (also stored in cabinet lid).
- B) The receiver is normally supplied ready for portable field operation: e.g. Battery supply module LP3627 fitted. The cabinet lid can be completely removed, by releasing the two retaining catches.

A small, protection cover-plate is provided, which safe'guards the IF OUTPUT and ANCILLARY sockets located at the rear of the cabinet. Access to these sockets is achieved by slackening-off the cover-plate retaining screws: swing the cover plate to one side and lock in position by tightening the relevant retaining screw. A similar arrangement is incorporated for the protection of the "whip" aerial socket located on the right-hand side of the receiver. The "whip" aerial is stored in the cabinet lid and is held firmly in place during transit by the lid mounted anchorage clips.

- C) To convert the receiver to mains AC operation; remove the battery supply module fitted on the rear of the receiver and substitute the unit for the mains power supply module (the relevant supply modules are stored in the cabinet lid when not in use). When fitted into the receiver, the supply units are held in place by two special anchored screws. NOTE: Care should be taken when removing either power supply module from the receiver to ensure that the connector has been released (located at right-hand side of unit when viewed from rear).
- D) The receiver carrying handle is adjustable and can be set securely in any one of three positions to facilitate ease of operation. A simple locking pin arrangement is provided at each pivot point (the locking pin mating with one of three recesses).
- E) Input and Output Sockets.
- (1) Input Socket: : 50Ω impedance. The socket is a BNC type connector located on the left-hand side of the receiver front panel. The receiver is calibrated in terms of the RMS value of the sinewave equivalent of the signal level p.d. applied to the input. The input is principally used for the measurement of conducted RF interference via a suitable mains "V" network, or for the measurement of field strength via a separate calibrated aerial. In both cases, the relevant correction factor (taken from Tables supplied with the "V" network and calibrated aerial) must be applied to the reading obtained.

(2) IF Output: : A standard BNC type socket is provided on the receiver rear panel, beneath the small protection cover-plate (note B of this section refers). The output impedance is several hundred ohms; an emf output of not less than 50mV p. to p. is obtainable at 1.75MHz with a sinewave input of a level to give "SET-CAL" reading on the meter. (See Operating Instructions).

(3) Ancillary Socket: : A standard 240° 5 pin DIN socket is provided with the following input/outputs. (Fig. 1 refers).

Pin 1 : : Ground

Pin 2 : : AGC Extra Time Constant - Used for additional external capacitor to increase AGC circuit time constants.

Pin 3 : : Detector Output - derived from the internal rectifier stage, giving an output of not less than 150mV across a 10MΩ load with an input signal of a level to give "SET-CAL" reading on the meter. The output impedance is several MΩ.

Pin 4 : : External Power Supply Input - used to power the receiver from an external supply source. NOTE that the Battery or Mains power supply modules (LP3627 or LP3618 respectively) should NOT be connected when power is derived from an external supply source. Refer to note F of this section (Power Supplies) for relevant details.

Pin 5 : : Ground.

Fig. 1. IF OUTPUT SOCKET and ANCILLARY CONNECTIONS VIEWED FROM REAR OF RECEIVER.

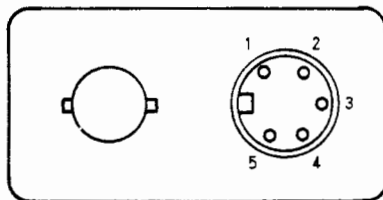

(4) "Whip" aerial socket: : A "Series UHF" connector is provided to facilitate operation with the "Whip" aerial supplied. NOTE; this socket should only be used for connecting the "Whip" aerial, otherwise the overall specification characteristics will not be met.

The socket is located beneath a protection cover-plate situated on the right-hand side of the receiver cabinet (note B of this section refers to protection cover-plate).

F) Power Supplies:-

(1) THE BATTERY POWER SUPPLY MODULE : requires six International Type D dry cells (or equivalent U2 types). Polarities are indicated on the module itself and the interconnecting plug/socket is colour coded to show polarity.

(2) THE MAINS POWER SUPPLY MODULE : is suitable for 40-60Hz AC mains operation in the range 190-270V (without changing transformer voltage taps). For 105-125V 40/60Hz conversion, refer to (4) below.

CAUTION If the cover is removed from the module, extreme care must be taken if the mains voltage is applied.

An integral mains lead of approximately 2m length is supplied with a standard 13 amp (BS 1363) plug FITTED WITH A 3 AMP FUSE. When fitting an alternative plug connector (to suit the local outlet) observe the following colour code:-

LINE	::	BROWN
NEUTRAL	::	BLUE
EARTH	::	GREEN/YELLOW

All primary and secondary fuses in the power supply module are 500mA rating. Spare fuses are supplied in the accessory pack. The maximum power consumption with 240V AC mains input is of the order of 3VA.

(3) EXTERNAL POWER SUPPLY UNIT : NOTE, BOTH THE BATTERY SUPPLY MODULE AND THE MAINS SUPPLY MODULE ARE REMOVED FROM CIRCUIT.

The external DC power supply (V+ applied to pin 4 of the ANCILLARY connector) should be in the order of +8.0V to +10.5V. The supply should have an output current capability of about 250mA (quiescent current 100mA approx).

The input at pin 4 of the ANCILLARY connector is diode protected against possible voltage polarity reversal.

The "CHECK BATT" facility (see Section 3, "Operating Instructions") can be used to ensure that the input voltage is within the required range.

(4) MAINS POWER SUPPLY MODULE CONVERSION DATA.

105 - 125V 40/60Hz AC.
190 - 270V 40/60Hz AC.

The socket is located beneath a protection cover-plate situated on the right-hand side of the receiver cabinet (note B of this section refers to protection cover-plate).

F) Power Supplies:-

(1) THE BATTERY POWER SUPPLY MODULE : requires six International Type D dry cells (or equivalent U2 types). Polarities are indicated on the module itself and the interconnecting plug/socket is colour coded to show polarity.

(2) THE MAINS POWER SUPPLY MODULE : is suitable for 40-60Hz AC mains operation in the range 190-270V (without changing transformer voltage taps). For 105-125V 40/60Hz conversion, refer to (4) below.

CAUTION If the cover is removed from the module, extreme care must be taken if the mains voltage is applied.

An integral mains lead of approximately 2m length is supplied with a standard 13 amp (BS 1363) plug FITTED WITH A 3 AMP FUSE. When fitting an alternative plug connector (to suit the local outlet) observe the following colour code:-

LINE	::	BROWN
NEUTRAL	::	BLUE
EARTH	::	GREEN/YELLOW

All primary and secondary fuses in the power supply module are 500mA rating. Spare fuses are supplied in the accessory pack. The maximum power consumption with 240V AC mains input is of the order of 3VA.

(3) EXTERNAL POWER SUPPLY UNIT : NOTE, BOTH THE BATTERY SUPPLY MODULE AND THE MAINS SUPPLY MODULE ARE REMOVED FROM CIRCUIT.

The external DC power supply (V+ applied to pin 4 of the ANCILLARY connector) should be in the order of +8.0V to +10.5V. The supply should have an output current capability of about 250mA (quiescent current 100mA approx).

The input at pin 4 of the ANCILLARY connector is diode protected against possible voltage polarity reversal.

The "CHECK BATT" facility (see Section 3, "Operating Instructions") can be used to ensure that the input voltage is within the required range.

(4) MAINS POWER SUPPLY MODULE CONVERSION DATA.

105 - 125V 40/60Hz AC.
190 - 270V 40/60Hz AC.

The relevant printed circuit board link data is clearly illustrated below for both voltage range options.

IT IS ESSENTIAL TO AFFIX THE RELEVANT INPUT LABEL FOR THE CORRECT VOLTAGE RANGE, EXTERNALLY ON THE MODULE WHEN A LINK CHANGE HAS BEEN MADE.

The labels supplied with the accessories are as follows:-

LOW VOLTAGE INPUT LABEL (105 - 125V) Part No. 10316P.

HIGH VOLTAGE INPUT LABEL (190 - 270V) Part No. 10317P.

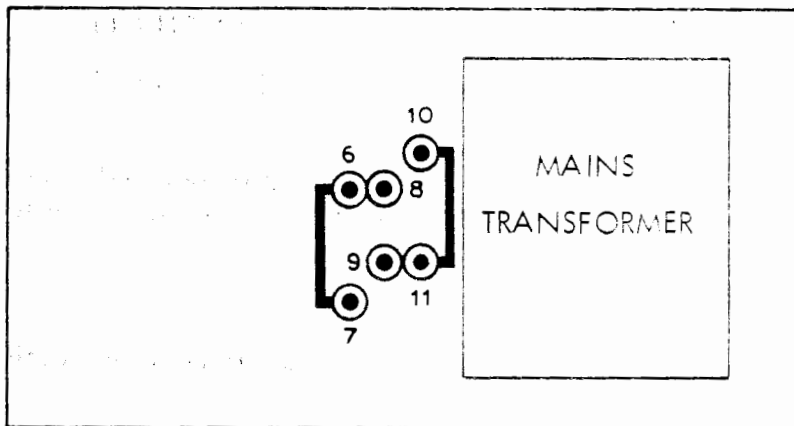

PCB LINK ARRANGEMENT FOR 105 - 125V 40/60Hz AC.

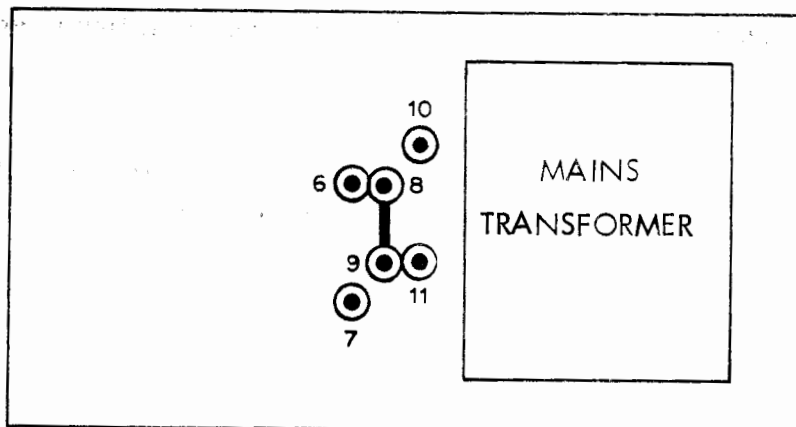

PCB LINK ARRANGEMENT FOR 190 - 270V 40/60Hz AC.

Section 3

OPERATING INSTRUCTIONS

Receiver Controls

PUSH BUTTON SWITCHES : : Colour Coded Red, Black and Grey:-
Red Button is the power On/Off switch.
Grey Buttons are used to select the required input.
Black Buttons are used to select the required operating function.

NOTE: : The above switches are self-lock/self-cancel types and operate as follows:-

BUTTON DEPRESSED = SWITCH ON

BUTTON RELEASED = SWITCH OFF.

TUNING SCALE ILLUMINATION : : A biased push button is provided and is marked "ILLUM". When held in the depressed position the tuning scale will be illuminated.

3-WAY TOGGLE SWITCH : : The switch positions (and respective functions) are marked as follows:-

"CISPR" - "BATT CHECK" - "LONG".

AF GAIN CONTROL : : Provides adjustment of the output level for the internal loudspeaker and the "PHONES" output socket.

FREQUENCY BAND SWITCH: : An eight position rotary action switch selects the required Frequency Range.

TUNING CONTROL : : Used in conjunction with the Frequency Band switch, to enable the tuned frequency to be set.

SET CAL CONTROL *

dB_μV (ATTENUATOR) *

METER *

NOTE: The control items marked * above are used to carry out the required measurements as described in the following text. ("Measurement Procedure" refers).

Operating Preliminaries

- 1) Switch on receiver by depressing the RED button. Check the internal battery state as follows:
 - (a) Set the CISPR - BATT CHECK - LONG toggle switch to the central "BATT CHECK" position.
 - (b) The green section of the METER scale now indicates the optimum range of supply voltage. Note that this check facility may also be used to set an EXTERNAL supply voltage source if necessary.
 - (c) NOTE : : Operation marginally outside of the indicated voltage range (green scale) is possible, but accuracy may be impaired.
 - (d) Set the CISPR - BATT CHECK - LONG toggle switch to either the "CISPR" or "LONG" position as required.
- 2) Set the FREQUENCY BAND SWITCH and adjust the TUNING CONTROL to the signal or frequency of interest.
- 3) Set the AF GAIN CONTROL to obtain the desired output level at the internal monitor loudspeaker, or at the PHONES drive socket.
- 4) The PHONES drive jack socket is a low impedance output capable of supplying greater than 100mW into 8 Ω and is therefore suitable for use with a wide range of loudspeaker or headphone impedances. When a jack plug is inserted into the PHONES socket, the internal monitor loudspeaker is automatically muted.

Measurement Procedure : : Using 50 Ω input ("RF INPUT 50 Ω ")

- 1) Ensure "AGC" is off.
- 2) Ensure "CISPR - BATT CHECK - LONG" toggle switch is set to either "CISPR" or "LONG" as required.
- 3) Ensure "IF + 20dB" is off.
- 4) Ensure "BFO" is off.
- 5) CALIBRATE RECEIVER AS FOLLOWS:-
 - (a) Ensure all INPUTS are off (grey switch buttons released).
 - (b) Switch calibrator ("CAL") ON.
 - (c) Adjust "SET CAL" control to obtain "SET CAL" reading on METER (calibration from internal impulse calibrator signal).
 - (d) Switch calibrator ("CAL") OFF.

NOTE: this sequence (items (a) to (d) above) must be performed at ALL relevant measurement frequencies prior to making the actual measurement.

- 6) Connect source of signal to be measured to the "RF INPUT 50Ω" (BNC) socket and select this input only (via relevant grey button switch).
- 7) Adjust the "dBμV" (ATTENUATORS) to obtain "SET CAL" reading on METER (e.g. "SET CAL" meter reading derived from the external signal or interference applied to "RF INPUT 50Ω" socket).
- 8) Note; the actual VALUE settings of the two "dBμV" (ATTENUATORS) now indicates the RMS value of the sinewave input (p.d.) equivalent to the signal being measured.
- 9) For signal levels greater than 80dBμV equivalent, use should be made of the "IF +20dB" switch facility. In this case, 20dBμV should be added to the level indicated on the "dBμV" (ATTENUATORS).
- 10) It is essential to note that any correction factors that may be necessary due to the measurement method (e.g. via a "V" network) should now be added to the reading shown on the "dBμV" (ATTENUATORS).

Measurement Procedure : : RF tracing using "internal loop" or "whip" aerial supplied:-

- 1) Select "LOOP" or "WHIP" input as required via relevant grey button switch.
- 2) If "WHIP" has been selected, connect the extendable aerial (stored in receiver cabinet lid) to the relevant UHF - type socket located beneath the protective cover plate on the rear RH side of the cabinet (Section 2, Item E part (4) refers).
- 3) For general monitoring purposes, select "AGC" on.
- 4) For tracing purposes, ensure "AGC" is off.
- 5) Adjust the input attenuators ("dBμV") to set the signal within the dynamic range of the receiver; preferably within the range of the METER scale.

NOTE: The reading obtained has no direct relationship with the signal level.

Note also that the "IF + 20dB" facility may be necessary in order to reduce the higher quiescent noise level present when "loop" or "whip" inputs are used.

- 6) To obtain relative readings of signal strength at a given frequency, the calibration procedure previously described may be used.
- 7) When tuning for sinusoidal signals, the "BFO" facility may be selected. This facility will produce an audible beat note when tuning is close to the signal. The "BFO" should then be switched off.

Eddystone

MODEL 40A
BOOK 2

Tech. Pubs.

TECHNICAL INFORMATION AND SERVICE DATA

A GEC MARCONI COMMUNICATIONS COMPANY
Eddystone Radio Limited,
Unit 8/9 Birkdale Avenue, Heeley Road, Selly Oak,
Birmingham B29 6UB.
Telephone: +44(0) 121 471 2600
Facsimile: +44(0) 121 471 4200
Telex: 99201



NOTE : : AC MAINS CONNECTOR

The following information is issued in compliance with British Standard BS415:-

If the colours of the wires in the mains lead of this apparatus do not correspond with the coloured markings identifying the terminals in your mains connector (or plug) proceed as follows:-

1. The GREEN/YELLOW wire must be connected to the plug terminal marked "E" or "  " or coloured GREEN or GREEN/YELLOW.
2. The BLUE wire must be connected to the plug terminal marked "N" or coloured either BLUE or BLACK.
3. The BROWN wire must be connected to the plug terminal marked "L" or coloured either BROWN or RED.
4. If a 13 amp (BS1363) FUSED PLUG is used to facilitate connection to the supply outlet, the plug MUST be protected by a 3 AMP FUSE unless expressly declared otherwise (see para. 5 below). If another type of plug is used, a fuse of the appropriate rating must be fitted either in the plug, or the adaptor, OR AT THE DISTRIBUTION BOARD.

5. NOTE:

A 3 AMP fuse rating is sufficient for most equipments, but in some instances, to allow for switching surges, it may be necessary to use a 5 AMP FUSE RATING. In all instances where the higher rating is applicable, specific notice will be given in the INSTALLATION SECTION of the handbook at the POWER SUPPLIES subsection.

Eddystone

NOISE MEASURING SET

MODEL 40A

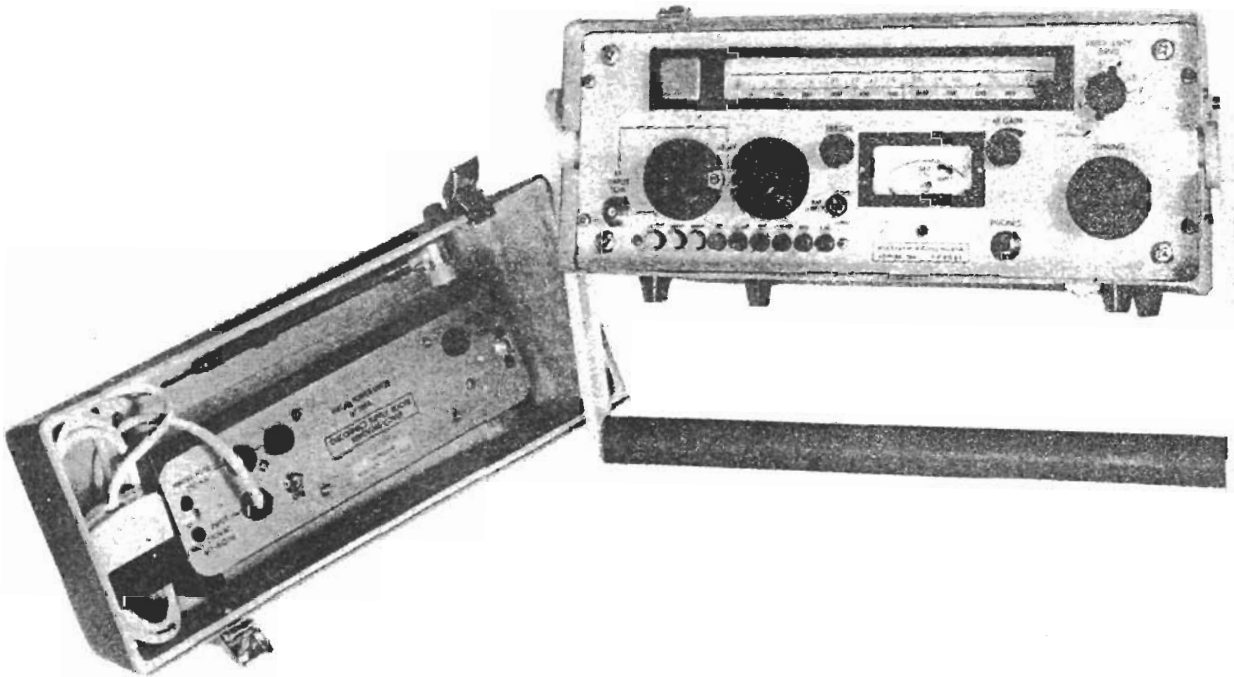

Manufactured in England by



EDDYSTONE RADIO LIMITED

MEMBER OF MARCONI COMMUNICATION SYSTEMS LIMITED
ALVECHURCH ROAD, BIRMINGHAM B31 3PP

Telephone: 021-475 2231

Telex: 337081



ISSUE NUMBER 1 JANUARY 1980

PRINTED IN ENGLAND

AMENDMENT RECORD

Amend No.	Pages subject to change	Amended by	Date
1			
2			
3			
4			
5			
6			
7			
8			
9			
10			
11			
12			
13			
14			
15			
16			
17			
18			
19			
20			
21			
22			
23			
24			
25			
26			
27			
28			
29			
30			

The Manufacturer reserves the right to modify the content of this publication as necessary to accommodate modifications, design improvements etc. Relevant Amendment Sheets will be incorporated at date of issue.

RADIO RECEIVER TYPE 40A

INTRODUCTION

General

This handbook provides the detailed Circuit Description and comprehensive Maintenance Instructions applicable to Radio Receiver type 40A (British Home Office design) manufactured by Eddystone Radio Limited.

It is important to note that Book 1, which is a separate publication, provides the necessary information concerning Commissioning and Receiver Operation. It is therefore essential to refer to Book 1 whenever detailed operating instruction is required, (Sections 1 to 3).

General Description

Radio Receiver type 40A, is a portable Radio Frequency Interference (RFI) measuring set, designed to meet the special requirements of the British Post Office and, in general, the special requirements of the specification set down in CISPR (16). The equipment is primarily intended for use by personnel engaged in the investigation of RFI in the frequency range 130kHz to 30MHz. The receiver is also ideally suited to many industrial uses, including acceptance testing on a wide range of electrical appliances.

Measurements can be taken of the voltage or field strength of CW signals, or impulsive noise with pulse reception frequencies as low as 1Hz. Integral ferrite loop aeriels or the "whip" aerial supplied, are utilized for interference tracing. Separate correction and conversion tables are supplied with calibrated aeriels specifically intended for field strength measurements or radiated noise measurements, or to facilitate the assessment of conducted noise using a suitable artificial mains network.

CIRCUIT DESCRIPTIONNOTES: SECTION FORMAT

Book 2

1) MODULAR CONSTRUCTION

The individual reference number allocated to the various components which make up a particular circuit module will always start at "1" (e.g. R1, C1 etc).

Each component reference in the description which follows is prefixed by the particular Module reference number to facilitate the location of the component.

Each RF Range has its own RF amplifier/mixer/oscillator module which is selected, as required, to drive the IF circuitry in the "MAIN IF" module. The RF amplifier modules are termed "LF HEADS" on the four lowest frequency ranges (1-4) and "HF HEADS" on the four highest frequency ranges (5-8) making a total of 8 modules.

On each LF HEAD the majority of the components are identical - the same applying for each HF HEAD. Components which differ from range to range as well as having the module prefix have a suffix numerically equal to the range number on which they are fitted.

The overall coding is as follows:

Prefix	1	-	LF HEAD (suffixes /1 to /4)
	2	-	HF HEAD (suffixes /5 to /8)
	3	-	MAIN IF
	4	-	CONTROL BOARD
	5	-	AERIAL AMPLIFIER
	6	-	ROD AERIALS
	7	-	POWER SUPPLY
	8	-	MISCELLANEOUS - CHASSIS - RANGE SWITCHES.

EXAMPLES: 3RV1 : Potentiometer located in MAIN IF MODULE
2L2/6 : Inductance located in range 6 HF HEAD.

2) CIRCUIT DIAGRAM

The following detailed description of the individual module circuitry should be read in conjunction with the main circuit diagram contained at the rear of this handbook. This diagram also contains information with regard to voltage and signal levels and should be used with reference to the 'MAINTENANCE' SECTION of this handbook. It is emphasized that the specified levels, unless otherwise stated, are typical values only.

LF HEADS : : COMPONENT PREFIX 1

The LF HEADS (module part nos. LP3616/5 to LP3616/8 for ranges 1 to 4 respectively), amplify the input signal fed via the aerial and the 1 & 10dB step attenuators, and convert it to the 1.75MHz intermediate frequency. The input and output, Vcc line and tuning capacitor

gang are only switched to the particular head in use, via switch 8S1A-F inclusive.

The input signal is fed via the step attenuator and switch 8S1F to a tap on the tuned input RF coil, 1L1/-. The position of this tap, combined with at least 10dB of attenuation, provides an overall input impedance (at the front panel socket) of $50\Omega \pm 5\Omega$. Another tap on this coil feeds the common source dual gate FET 1TR1 (40673) which amplifies the signal and provides the output across the tuned mixer coil, 1L2/-. One input of the balanced mixer 1IC1 (SG3402) is driven via a tap on coil 1L2/- and the other input receives the variable first oscillator drive from the dual gate FET 1TR2 (40673). This is connected in the single gate mode as a capacitive feedback tuned oscillator using the coil 1L3/-. The three coils are tuned simultaneously by three sections of the main tuning gang (8C3-5).

The mixing action of 1IC1 provides an output at 1.75MHz which is fed to the MAIN IF module. The balance of this mixer is adjusted by 1RV1 to enable maximum rejection of input signals at 1.75MHz being fed to the IF amplifier. The gains of different head modules in a given receiver can be partially equalized by adjustment of the oscillator level using potentiometer 1RV2.

HF HEADS : : COMPONENT PREFIX 2.

The HF HEADS (module part nos. LP3616/9 to LP3616/12 for ranges 5-8 respectively), amplify the input signal (fed via the 1 & 10dB step attenuators) and convert it to the 1.75MHz intermediate frequency. The input and output, Vcc line and tuning capacitor gang are only switched to the particular head in use via switch 8S1A-F inclusive.

The input signal is fed via the step attenuators and 8S1F to a tap on the tuned input RF Coil, 2L1/-. The position of this tap combined with at least 10dB of attenuation provides an overall input impedance (at the front panel socket) of $50\Omega \pm 5\Omega$. Another tap on coil 2L1/- feeds the common source dual-gate FET 2TR1 (40673) which amplifies the signal and provides the output across the tuned mixer coil, 2L2/-. The signal across the whole of this coil is fed to gate 1 of the dual-gate FET mixer, 2TR2 (40673). Gate 2 of this device receives the variable first oscillator drive from the dual gate FET 2TR4 (40673), which is connected in the single gate mode as a capacitive feedback tuned oscillator using coil 2L4/-. The three coils 2L1/-, 2L2/- and 2L4/- are tuned simultaneously by three sections of the main tuning gang (8C3-5).

The mixing action of 2TR2 provides an output at 1.75MHz which is filtered by the tuned circuit consisting of 2L3 and 2C15. The secondary of the coil feeds 2TR3 (BC547B), which is connected as an amplifier with preset negative feedback. Adjustment is provided via 2RV1 in order to partially equalise the gains of different head modules in a given receiver. 2TR3 provides an output across 2R14 which is fed to the 'MAIN IF' module. 2R14 provides the correct source impedance for that module.

MAIN IF : : COMPONENT PREFIX 3

The MAIN IF (module part no. LP3616/2) contains the 1.75MHz IF amplifier and filter, the quasi-peak detector and meter drive DC amplifier, the AGC, BFO, detector, audio amplifier and finally the impulse calibrator. This module is plugged into the CONTROL BOARD via SK2 which holds the majority of the front panel switching and is hard-wired to the remaining controls. The CONTROL BOARD is described in the next sub-section.

The signal from either the LF or HF Head in use is fed to the Main IF module input via switch 8S1C. The input is filtered by 3FL1 (crystal filter), which determines the overall receiver bandwidth (typically 9kHz). The signal is then passed to 3TR1 (40673), a common source amplifier with a tuned load formed by 3L1 and 3C3. The output from the secondary winding of 3L1 is fed to 3IC1 and 3IC2 (SL612) which provide the bulk of the IF amplification. The amplifiers formed by 3IC1 and 3IC2 are of the variable gain type, and this facility is used in the AGC, IF +20dB and SET CAL operations. When AGC is selected via switch 4S6, the gain of 3IC1 is controlled by the AGC rectifier output; otherwise the gain is set by the position of the 'IF +20dB' switch 4S7. When 4S7 is switched out, 3IC1 gain is fixed by the voltage on the potential divider formed by 3R52 and 3R53. When 4S7 is switched in, ('IF +20dB' is selected), the gain is reduced by approximately 20dB. This reduction is preset by adjustment of the variable potential divider formed by 3R54, 3RV4 and 3R55. The gain of 3IC2 is adjusted by the SET CAL control (8RV1) as part of the calibration procedure undertaken before each measurement, in order to standardise the receiver gain. The supply for the potential dividers, the 'SET CAL' pot, 3IC1 and 3IC2 are stabilised by zener diodes 3D2, 3D10, 3D1 respectively (BZX79 C5V6).

The output of 3IC2 is fed to 3TR2 (BC107B). The configuration is that of a common emitter amplifier with a broad-tuned step-up transformer (3L2) as the output load. This circuit arrangement provides sufficient output drive for the quasi-peak detector diode 3D4 (1N916) to enable measurements of impulses with very low repetition frequencies. The diode (3D4) and associated resistors and capacitors, form a quasi-peak detector of characteristics suitable to give the required response. The electrical charge time is determined by 3L2, 3D4 and the preset charge capacitors 3C15/C16. The electrical discharge time is determined by 3C15/16 and the resistors 3R15 and 3R17. A portion of the rectified voltage is fed via 3R18 to the differential amplifier formed by 3TR3 and 3TR4 (UC734B); the differential output across 3RV1 drives the moving coil display meter. The amplifier gain and balance are preset by potentiometers 3RV2 and 3RV1 respectively. The voltage fed to this amplifier stage is also directed to the rear panel ancillary socket (8SK4) via 3R16.

A pre-quasi-peak detector output from 3L2 drives the IF output buffer 3TR5 (BC547B) and the envelope/product detector 3TR7 (40673) via 3R14. 3TR5 feeds the rear panel IF output socket 8SK4 and also the AGC amplifier 3TR10 when AGC is selected with switch 4S6. 3TR7 (40673), in conjunction with the step-up coil 3L4 and diode 3D7 (OA47) operate as a conventional envelope detector for AM signals, or as a product detector when gate 2 is driven from the output of the BFO transistor 3TR6 (40673). Transistor 3TR6 is connected in a single gate configuration to function as a capacitive feedback oscillator at about 1.75MHz, the frequency being preset by coil 3L3. The oscillator is switched on by applying voltage to the drain (via BFO switch 4S8) and the stabilising zener diode 3D6 (BZX79 C5V6).

The audio output of the detector circuit is fed via the CONTROL BOARD and front panel AF gain control (8RV2) to the audio amplifier 3IC8. The audio stage can provide more than 100mW into the internal monitor loudspeaker or into an 8Ω load connected across the front panel 'PHONES' socket (8SK1).

Transistor 3TR9 provides sufficient amplification to drive the AGC detector diode 3D8 (BAX13). The rectified voltage developed across 3C39 and 3R38 is fed back to the IF amplifier 3IC1, when AGC is selected with switch 4S6, via 3TR8 (BC214).

The impulse calibrator consists of 3TR10 and 3TR11 (2N2369A) cross-coupled to form an astable multivibrator, which generates a narrow steep-sided pulse with a repetition frequency in the order of 100Hz. The pulsed waveform is differentiated and attenuated by the network comprised of 3C44, 3R44, 3R45 and 3RV3, to give an impulse with a reasonably flat frequency spectrum up to 30MHz and a spectral intensity in the order of $47\text{dB}\mu\text{V}/\text{MHz}$. The 'flatness' of the spectrum is pre-set using 3C44 and the level using 3RV3. In practice, the level is set to be equivalent to a $0\text{dB}\mu\text{V}$ sinewave input signal (p.d.). The calibrator voltage supply is stabilised by zener diode 3D9 (BZX79 C5V6).

CONTROL BOARD : : COMPONENT PREFIX 4

The control board (part no. LP3616/1) acts as an interface between the MAIN IF, the wiring loom and the hardwired front panel controls. The Board also holds the row of nine push-button switches.

The push-buttons have the following functions:-

- 4S1 - 'INPUT'. Depression of this switch connects the front panel 'RF INPUT 50Ω ' to the input of the 10dB step attenuator and thence to the 1dB step attenuator and LF or HF Head selected.
- 4S2 - 'LOOP'. Depression of this switch connects the output of the aerial amplifier to the input of the 10dB step attenuator etc. It also connects the voltage supply line to the aerial amplifier with the main Vcc supply bus on the control module printed circuit board. This effectively means that the receiver is fed from the internal ferrite rod aeriels.
- 4S3 - 'WHIP'. Depression of this switch has the same effect as 4S2 and also switches relay 5RLA, which directs the aerial amplifier input to the whip aerial socket on the cabinet right hand side. The extendable whip aerial then attached to the 'WHIP' socket is thus the effective signal source for the receiver.
- 4S4 - 'ON'. Depression of this switch connects the voltage supply from internal or external power supply (via the wiring loom) to the main Vcc bus on the Control Board. The receiver is thus switched on.
- 4S5 - 'ILLUM'. Depression of this biased switch illuminates the tuning scale for the purposes of checking frequency of tune under poor ambient lighting conditions.
- 4S6 - 'AGC'. Depression of this switch connects the output of the IF amplifier, via 3TR5, to the input of the AGC amplifier 3TR9. Also, the rectified output of the AGC amplifier (via 3TR8) is connected to the gain control input of 3IC1.

- 4S7 - 'IF +20dB'. This switch is only effective when AGC (4S6) is not depressed. When 4S7 is in the DEPRESSED state, the switch determines the gain control voltage fed to 3IC1 via 4S6. When 4S7 is RELEASED, the voltage is set by the potential divider 3R52 and 3R53. When 4S7 is DEPRESSED, the voltage is determined by the preset potential divider formed by 3R54, 3R55 and 3RV4; (preset to give a gain reduction of approximately 20dB).
- 4S8 - 'BFO'. Depression of this switch activates the BFO stage (3TR6) by connecting it to the main Vcc supply bus on the Control Board.
- 4S9 - 'CAL'. Depression of this switch activates the impulse calibrator circuit (3TR10 and 3TR11) by connecting the circuit stage to the main Vcc supply bus on the Control Board. 4S9 switches the calibrator output to the input of the HF or LF Head in use (via switch 8S1F).

AERIAL AMPLIFIER : : COMPONENT PREFIX 5

The Aerial Amplifier (module part no. LP3616/13) contains a wideband amplifier which matches the whip aerial (or the internal unbalanced ferrite rod loop aeriels) to the 50Ω input of the receiver. The amplifier stage also incorporates a set of coils, one for each range, which act as tuned loads for the whip aerial.

The whip aerial is switched (via 8S1I) to a coil which is tuned simultaneously with the relevant Head RF, mixer and oscillator coils. Similarly, the balanced lines from the ferrite rod aerial coils are switched via 8S1H and 8S1G to the rear two (used) sections of the tuning gang. When 'WHIP' is selected using 4S3, relay 5RLA is activated, feeding the output across the whip tuned circuit to the tuning capacitor 8C6 and one of the balanced aerial amplifier inputs. This open circuits one of the ferrite rod balanced lines effectively making them inoperative. When 'WHIP' is not selected, the balanced lines of the selected ferrite rod coil are directed to the ganged tuning capacitors 8C6 and 8C7 and thence to both inputs of the balanced amplifier.

Transistors 5TR1 and 5TR2 (UC734B) form the balanced differential amplifier. The coil 5L9 provides a wideband load, with the unbalanced output being taken to the base of 5TR3 (BFX89). This further amplifies the signal and drives the broadband output transformer 5L10. The output derived from 5L10 is switched through to the 10dB step attenuator input when either 'LOOP' or 'WHIP' is selected (and thence via the 1dB step attenuator and switch 8S1F to the relevant LF or HF head in use). Transformer 5L10 also provides circuit stage impedance matching. Supply voltage is fed to 5TR1, 5TR2 and 5TR3 only when either the 'LOOP' or 'WHIP' switches are depressed. Relay 5RLA is only activated when the 'WHIP' switch is depressed.

ROD AERIALS : : COMPONENT PREFIX 6

The Rod aeriels printed circuit board (part no. LP3616/14) holds the internal ferrite rod or 'loop' aeriels and their associated padding and trimming capacitors.

The rod aeriels are comprised of windings on movable carriers fitted around ferrite rods. The coil winding carriers are fixed in place during the alignment procedures. The balanced output of the relevant rod aerial winding is selected by the RANGE SWITCH sections.

Switch wafers 8S1H and 8S1G are fed to the tuning gang sections (8C6 and 8C7) and thence to the inputs of the balanced aerial amplifier (5TR1 and 5TR2). When 'WHIP' is selected, one of the inputs is redirected from the ferrite rod aerial to the 'WHIP' aerial.

POWER SUPPLY : : COMPONENT PREFIX 7

This module (which is interchangeable with the battery power supply) enables standard mains operation via a 40-60Hz AC supply voltage in the range 105-125/150-270V. The part number for the complete module is LP3618. (The printed circuit board assembly alone is LP3616/15).

The integral mains input lead is connected to the primary of the printed circuit mounting transformer via a fuse in each line, and the incorporated mains filter. The filter (which reduces common mode mains interference) consists of two 'Y' class capacitors (7C1, 7C2), one from each supply line to ground, a balanced mains choke (7L1) and an 'X' capacitor (7C3) from line to neutral. The transformer secondary feeds the full wave rectifier bridge formed by 7D1 - 7D4 (IN4004) via the secondary fuse. The smoothed bridge output is regulated by 7IC1 (MC7808CP) and fed to the receiver Vcc bus on the Control Board via the wiring loom and 'ON' switch 4S4.

MISCELLANEOUS - CHASSIS - RANGE SWITCHES : : COMPONENT PREFIX 8

The principal features are the front panel hard-wired controls, the wiring loom, the range switch assembly and the tuning gang assembly.

All the hardwired front panel controls are connected to the CONTROL BOARD. The respective control operations are as follows:-

- 8RV1 - 'SET CAL'. Applies a variable voltage to 3IC1 which sets the gain during calibration procedure (i.e. gain standardisation). The voltage supplied to the top of this potentiometer is stabilised by the zener diode 3D10.
- 8RV2 - 'AF GAIN'. A conventional variable potentiometer connected between the envelope/product detector (3TR7) and the audio amplifier (3IC3).
- 8S2 - 'CISPR - BATT CHECK - LONG'. This three-position toggle switch controls the function of the meter. When switched to 'CISPR' the meter is connected to the balanced output of the DC amplifier formed by 3TR3 and 3TR4 and is thus driven by the output of the quasi-peak detector. When 8S2 is switched to 'LONG' the above configuration is maintained, but an extra capacitor, 8C1, is switched across the meter to alter the response to impulsive noise at low repetition frequency. When 8S2 is switched to 'BATT CHECK' the meter is connected between ground and the main Vcc bus on the CONTROL BOARD via a resistor. The voltage on the bus is thus indicated by the meter reading. The section of the meter marked in green indicates the optimum bus voltage and is used to check the battery condition, output of the mains power supply, or the setting of an external power supply input.

- 8SK1 - 'PHONES'. A standard 6.35mm ($\frac{1}{4}$ ") jack socket connected directly across the audio output line from 3IC3. When a plug is inserted, one line to the internal monitor speaker is open-circuited thus automatically muting the L.S.
- 8SK2 - 'RF INPUT 50 Ω '. A standard 50 Ω BNC connector wired to the 'INPUT' switch 4S1.
- 8AT1 and 8AT2 - 'INPUT ATTENUATORS'. The 10dB step, seven position; and 1dB step twelve position pair of 50 Ω attenuators are connected in series between the final output of the 'INPUT, LOOP and WHIP' switches (4S1-3) and one input of the 'CAL' switch (4S9) which directs the output to the LF or HF head selected (via 8S1F) unless 4S9 is depressed.

The wiring loom is attached via a multi-way plug and socket to the CONTROL BOARD. The loom also carries the relevant leads to the loudspeaker, ancillary outputs, aerial amplifier module and supply voltage input to the LF and HF heads (via 8S1A). The LF and HF heads are supplied via a lead separated from the main loom for purposes of isolation (via socket 8SK6).

The range switch assembly consists of six printed circuit switches (8S1A - 8S1F inclusive). Each switch section is mounted on an individual PCB sub-assembly (board part number LP3616/4). A further three switches (8S1G - 8S1H and 8S1I) are mounted on a metal bracket. The foregoing nine switch sections are all ganged with the front panel 'FREQUENCY BAND' control and accordingly select the relevant LF or HF head, together with the appropriate ferrite rod or whip aerial coil. The switch sub-assembly PCBs are permanently fixed to the 'RF CHASSIS' printed circuit board (part number LP3616/3) into which the LF and RF HEADS are plugged.

The tuning gang assembly consists of two, three section gangs, coupled to the drive and front panel 'TUNING' control. The first gang tunes the oscillator, mixer and RF coils of the LF or HF Head selected (via switches 8S1B, 8S1D and 8S1E respectively). The rear gang, of which only the first two sections are used, tunes the ferrite rod aerial selected via 8S1H and 8S1G or the whip aerial coil selected via 5RLA and 8S1I.

TECHNICAL DATA SUMMARY

Input impedance	:	$50\Omega \pm 10\%$ at the tuned frequency with 10dB or more attenuation being used.
Measurement range	:	(equivalent sinewave p. d. input) 0dB μ V to 100dB μ V with use of 'IF +20dB' facility. An extra ± 5 dB range at any point is obtainable using the meter, but with a slight reduction in accuracy (0.5dB).
Detector output	:	$\geq +150$ mV D.C. at 'SET CAL' reading on meter (output across 10M Ω load). Output is proportional to quasi-peak rectifier output voltage.
IF Output	:	≥ 50 mV p. to p. emf with a sinewave input giving 'SET CAL' on meter.
IF Frequency	:	1.75MHz.
External power supply input	:	+8.0 to +10.5V DC for optimum operation (n.b. this input is diode protected against accidental reversal of polarity).
Weight	:	= 10kg total package (approx).
Dimensions	:	WIDTH : 385mm including handle. HEIGHT : 161mm including feet. DEPTH : 358mm including feet.
Bandwidth	:	9kHz \pm 1kHz.
Bandwidth at 60dB	:	36kHz maximum.
Electrical charge time constant of rectifier circuit	:	approx 1mS.
Electrical discharge time constant of rectifier circuit	:	approx 160mS.
Mechanical time constant of critically damped meter (to 35% of steady deflection)	:	approx 160mS.
IF and image rejection (150kHz - 30MHz)	:	better than 40dB.
Spurious response rejection	:	better than 40dB.
Accuracy of sinewave voltage measurement	:	Within ± 2 dB (at 'SET CAL' mark on meter).

Screening	:	With the receiver in a RF field 80dB μ V/M in frequency range 130kHz - 32MHz, the indication on the meter shall not exceed 'SET CAL' after calibration.
Internal noise	:	Does not exceed -5dB point on meter after calibration.
Pulse response ('CISPR' selected).	:	Between 150kHz and 30MHz after calibration.

n.b. When 'LONG' is selected the variation in response at low prfs is widened by a few dB.

PRF (Hz)	Relative equivalent level of pulse for 'SET CAL' on meter (dB).
1000	-4.5 \pm 1.0
100 (ref)	0 (ZERO)
20	+6.5 \pm 1.0
10	+ 10 \pm 1.5
2	+20.5 \pm 2.0
1	+22.5 \pm 2.0
Isolated pulse	+23.5 \pm 2.0/ -3.0

Frequency calibration	:	Within \pm 2%.
Audio Output	:	At least 100mW into an 8 Ω load at the front panel phone jack.
Environmental	:	Equipment meets DEF 135 for category III equipment. Operating temperature - range -5 $^{\circ}$ C to +55 $^{\circ}$ C RH not exceeding 30% and 0 $^{\circ}$ C to 40 $^{\circ}$ C, RH not less than 95% at +40 $^{\circ}$ C.

Section 5

MAINTENANCE

1) RECALIBRATION

During the periodical service calibration check of the receiver, NOT the normal precalibration procedure performed before each measurement, the two most important parameters to check for conformity with specifications are as follows:-

- (i) Variation with P.R.F.
- (ii) Accuracy of sinewave voltage measurement.

Errors in the first parameter are an indication of a possible fault condition which would be of a magnitude comparable with that of the error.

Errors in the second parameter, if of a large and variable magnitude, would indicate a fault in the Calibrator circuit. Whereas, if the error is of a small and moderately variable magnitude (say 1-3dB) this would indicate that the system requires service recalibration as follows:

NOTE: the Receiver must be removed from the cabinet and the top cover must be removed.

- (a) Switch the receiver 'ON' and use the 'BATT CHECK' facility to test the Vcc voltage (i.e. the meter should give a reading in the green section).
- (b) Select 'INPUT' and ensure that 'LOOP, WHIP, AGC, IF +20dB and BFO' are not selected. Ensure the 'CISPR - BATT CHECK - LONG' is returned to CISPR.
- (c) Set the INPUT ATTENUATORS to 40dB μ V and introduce a 46dB μ V emf sinewave signal (40dB μ V into the 40A) from a 50 Ω generator at 2MHz, into the front panel socket 'RF INPUT 50 Ω '.
- (d) Tune the receiver exactly to the signal (FREQUENCY BAND 4) using the meter as a level indicator and adjusting the 'SET CAL' control leaving it in the end, so that the meter reads 'SET CAL'.
- (e) Switch off 'INPUT' and depress the 'CAL' switch. An output due to the impulse calibrator signal should be heard in the monitor loudspeaker (the 'AF GAIN' control may first need adjustment).
- (f) Adjust the calibrator output level to obtain 'SET CAL' on meter. This is done using the vertical preset potentiometer 3RV3 which is the lowest preset pot on the left hand side of the 'MAIN IF' printed circuit board (behind the 10dB Step attenuator).
- (g) This should be checked at frequencies in the middle of each Frequency Band, using the 'Measurement Procedure' on Page 3-2. In all cases the difference between the reading obtained from a 46dB μ V emf signal and the calibrator signal (adjusted at 2MHz) should not exceed 2dB. If it does, for differences greater than 2dB, slight experimental adjustments will need to be made to the impulse differentiating capacitor 3C44, adjacent to 3RV3, and steps (3) to (7) repeated until satisfactory.

- (h) Finally, a check should be made to establish that the $\pm 2\text{dB}$ accuracy of sinewave measurement (see operation) is maintained at the extreme ends of the attenuator and frequency range.

2) ERROR DIAGNOSIS

As indicated previously, large and widely variable errors in the 'Sinewave voltage measurement' is a probable indication of a Calibrator circuit error. Errors in (i) 'Variation with P.R.F.' (i.e. pulse response) would most probably be due to one (or more) of the following:-

- (a) Incorrect quasi-peak rectifier charge/discharge time constants, if errors occur mainly at medium to high P.R.F.'s.
- (b) Incorrect IF gain/dynamic range distribution, if the errors are occurring consistently and only at low P.R.F.'s.
- (c) Incorrect HF or LF Head gain, if the errors are occurring only at low P.R.F.'s on a specific range or ranges.

Severe errors in bandwidths may also cause such errors. The bandwidth is determined by the MAIN IF crystal filter 3FL1. Only a major fault in other tuned circuits is likely to affect the receiver overall bandwidth.

Errors in IF and image rejection and frequency calibration indicate that re-alignment of the appropriate LF/HF Heads, RF mixer and oscillator tuned circuits is required. Also if the 'Loop' and 'Whip' aerials lack sensitivity, the rod aerials and whip aerial coils may need re-alignment.

Measurement of bandwidths is made by increasing the input level by 6 or 60dB and noting the frequency offsets necessary to maintain a standard output ('SET CAL') on the meter. Measurement of image (3.5MHz above frequency of tune) and IF rejection (1.75MHz) is made by noting the dB increase of these frequencies (relative to the level at the frequency of tune) necessary to maintain the standard output. It should be noted that these characteristics are only specified for inputs via the RF INPUT 50 Ω socket 8SK2.

3) TEST AND ADJUSTMENT OF MODULES

The relevant modules/adjustment points are illustrated at figures 5-1 to 5-4 inclusive. These internal views should be used in conjunction with the following notes.

Introduction

The circuit diagram, bound at the rear of this handbook, contains figures and data for voltage gains, drive levels, bandwidths and DC voltages. This diagram is an essential service aid and should be regularly consulted during test and fault-finding routines. It should however be emphasised that, unless otherwise stated, the specified figures are typical only. Again, unless otherwise stated figures are given for a sinewave input signal giving 'SET CAL' on meter and with the main Vcc bus at 8V (i.e. mains power supply fitted).

The following test equipment will be found to be of particular usefulness:-

- (1) OSCILLOSCOPE : : High frequency oscilloscope with 10nS/cm resolution and a maximum sensitivity of 50mV/cm with a x 10 probe (10M Ω , 7-12pF).
- (2) SIGNAL GENERATOR : : A stable signal generator of 50 Ω impedance, with accurate output levels (within +0.5dB) in the range 0dB μ V to 106dB μ V emf (utilizing an external attenuator if necessary). Amplitude modulation of 30% at 1kHz should also be possible.
- (3) IMPULSE GENERATOR : : An impulse generator with variable P.R.F. of at least 1Hz to 100Hz (preferably single pulse to 1kHz) with a drive capability equivalence of up to 100-110dB μ V rms/MHz into 50 Ω with an accurate output level (within +0.5dB) over the frequency range of the receiver (130kHz - 32MHz).
- (4) VARIABLE ATTENUATOR : : A variable attenuator with at least 35dB range in 1dB steps and an accuracy of better than 0.2dB at any step.

NOTE: The above basic details are given for guidance only. Eddystone Radio Limited, should be consulted for more comprehensive advice concerning test - equipment usage and evaluation methods.

MAIN IF Module

A major re-alignment or service check should commence with this module which contains most of the common functions. The module is plugged into the CONTROL BOARD and if both are removed, they can be operated together externally with temporary links to the controls remaining on the front panel. However, adjustments to the preset pots etc., on the MAIN IF can be performed with the module in position. To enable adjustment to some of the coils, the drum containing the frequency scale strips will need to be rotated (via the Frequency switch) so that the gap is opposite to the coils to be adjusted.

The alignment should proceed in the following sequence:-

- (i) A sinewave signal at 1.75MHz + 1kHz is introduced to the 'MAIN IF' input 3SK2 (adjacent 3FL1). The input level is increased until 150mV p to p is obtained (an undistorted sinewave should be obtained). The DC amplifier gain potentiometer 3RV2 should now be adjusted so that the front panel meter reads 'SET CAL'. With the input signal removed, the balanced potentiometer 3RV3 is adjusted so that the meter has no deflection. These two adjustments should be repeated until both are correct and free from any interaction error. The coils 3L1 and 3L2 should now be adjusted for maximum output. 3L2 has a very low working 'Q' and should not effect the output level greatly; if re-adjustment gives more than 1 or 2dB more output, the settings of 3RV2 and 3RV3 will have to be re-checked. (Note; the tuning of 3L2 is principally determined

by the selection of 3C14 during initial alignment). The preset pot 3RV4 should now be adjusted to give 20dB reduction in gain when the 'IF +20dB' switch is depressed. If necessary, a check on the gains and DC levels relevant to this circuit stage can also be made, with reference to the data on the circuit diagram. The bandwidth from 'MAIN IF' input to meter can also be checked and should be approximately equivalent to the overall bandwidth given in the 'Technical Data Summary'. For this measurement, the impedance of the 1.75MHz signal source should be 150Ω (i.e. a 50Ω generator with a 100Ω extra series resistor). Selection of the capacitors 3C15 and 3C16 (across test points TP3 and TP4 respectively) is made during initial alignment in order to obtain the correct charge/discharge time constants and thus the correct pulse response. All of the foregoing tests should be conducted with AGC off. With AGC selected the output level of 3TR2 collector should be stabilized at (very approximately) 150mV p. to p. over a wide range of input levels.

- (ii) With the 1.75MHz input signal amplitude modulated 30% at 1kHz, the detector coil 3L4 should be adjusted to give maximum audio output. With the modulation again switched off and with BFO selected, BFO coil 3L3 should be adjusted to obtain an audible output beat. As before, these tests should be conducted with AGC off, and again DC voltage levels and oscillator levels can be checked with reference to the circuit diagram.
- (iii) With the 1.75MHz input signal amplitude modulated 30% at 1kHz and with AGC selected and the input level well into AGC, the audio amplifier 3IC5 should be checked to ensure that, with maximum 'AF GAIN', an audio output power of 100mW can be delivered into an 8Ω load across the 'PHONES' socket.
- (iv) The final setting of the calibrator presets 3RV3 and 3C44 is carried out as per service recalibration described at the beginning of Section 5. However, the data on the circuit diagram can be used to check for actual faults and if a spectrum analyser (with a range 130kHz to 32MHz) is available, initial adjustment of 3C44 may assist recalibration later. To do this, a high impedance probe should be attached to 'A' and 3C44 adjusted to obtain a flat as possible (certainly within 2dB) frequency spectrum from 130kHz to 32MHz.

Control Board

This unit has no active functions and requires no adjustment. A basic check of the wiring loom via 4SK1, can be made as follows:

Coax leads in loom, working from rear of connector 4SK1.

- Lead 'A' (pin 20, screen pin 19). - 'Detector output' - takes the output from the quasi-peak detector (through resistor 3R16) to the rear panel DIN ancillary socket (via feedthrough on rear left hand side of receiver).
- Lead 'B' (pin 18, screen pin 17). - 'Loudspeaker drive' - takes audio output from 3IC5 (earth return via 'phones' socket) to the internal monitor loudspeaker.

- Lead 'C' (pin 15, screen pin 16). - 'IF Output' - takes IF output (from 3TR5) to the rear panel BNC socket.
- Lead 'D' (pin 14, screen pin 13). - 'AGC time constant' - takes the rectified AGC voltage line which connects the output of the AGC output transistor 3TR8 to the IF amp 3IC1, to the rear panel DIN connector (via feedthrough on rear left hand side of receiver).
- Lead 'E' (pin 10, screen pin 9). - Takes a line from the main Vcc supply bus on the Control Board to the voltage supply switch, 8S1A of the HF and LF Heads.
- Lead 'F' (pin 7, screen pin 8). - Supplies the main Vcc supply bus on the Control Board, from the rear power supply fitted, or from an external power supply via the rear panel DIN socket. This also goes via a feedthrough on the rear left hand side of the receiver.
- Lead 'G' (pin 5, screen pin 6). - Connects the main Vcc supply bus on the Control Board to the Aerial amplifier voltage supply input pin 1 whenever 'WHIP' or 'LOOP' are selected (switches 4S2 and 4S3). This lead travels via a feedthrough on the rear right hand side of the receiver. Note; when 'WHIP' is selected the lead also travels via diode 4D1 causing an extra slight voltage drop ($\approx 0.6V$).
- Lead 'H' (pin 4, screen pin 3). - Connects the relay coil (5RLA) supply on the Aerial amplifier module (pin 2) to the main Vcc supply bus on the Control Board whenever 'WHIP' is selected (switch 4S3). This lead travels via a feedthrough in the rear right hand side of the receiver.
- Lead 'I' (pin 1, screen pin 2). - This lead connects the output of the Aerial Amplifier module pin A, to the input of the 10dB step attenuator whenever 'LOOP' or 'WHIP' are selected (switches 4S2 and 4S3).

LF and HF Heads

The alignment of these modules follows normal procedure for variable tracked tuned circuits. However, alignment of a particular module generally requires the removal of all lower frequency heads (to obtain access to adjusters). Alignment of the RF and mixer circuits can also be facilitated by use of the calibrator signal as a source and the front panel meter as an output indicator. The procedure for full re-alignment is as follows. The tables 1,2 indicate the input frequencies and adjustment coils/trimmers number.

(i) Oscillator circuits:

With the receiver and generator tuned to the lower frequency tracking point, the appropriate oscillator coil is adjusted to give an output signal. Then, with the receiver and generator tuned to the high frequency tracking point, the appropriate oscillator trimmer is adjusted to give an output signal. These two adjustments should be repeated until both are correct and free from any interaction error. The oscillator level and purity can then be checked over the whole range at TP16. On the top 2 HF ranges, a check should be made that the image frequency lies on the HF side.

(ii) RF and mixer circuits:

With the Calibrator switched on and the receiver tuned to the lower frequency tracking point, the appropriate RF and Mixer coils are adjusted for maximum output on the meter. Then, with the receiver tuned to the higher frequency tracking point, the appropriate trimmers are adjusted for maximum output on the meter. These adjustments are repeated until all are correct and free from any interaction error. Also in the case of the HF Heads alone, the IF coils 2L4 (unaffected by tuning of receiver) must be adjusted for maximum output.

(iii) In case (i) and (ii) the input level and/or 'SET CAL' gain will need to be constantly adjusted to maintain the output within the range of the meter (AGC should be off). After all the heads have been satisfactorily aligned as above, the gain of each module must be equalised at the middle of each range, using 1RV1 for LF Heads or 2RV1 for HF Heads and using the calibrator as a wideband reference level. A maximum variation of 10dB overall is satisfactory. The variation over any one range should not be greater than about 12dB. For variation above this level a check of alignment of the RF and mixer coils should be made at the geometric centre tracking point (table 2). Re-adjustment of the RF and Mixer coils should not increase the gain at these points, by more than 1 or 2dB. A check can also be made of the scale frequency accuracy using an accurately calibrated signal generator or crystal marker calibrator. A scale accuracy of 2% should be maintained.

(iv) The final adjustment, which is made to the LF heads only, is the balance of IC1, the balanced mixer. With the receiver tuned as close as possible to 1.75MHz (though not closer than 100kHz) and with a 1.75MHz signal input producing a signal in the IF and giving a meter reading, 1RV2 is adjusted for minimum output. The operation is repeated for each LF Head.

Table 1 Oscillator alignment points

HEAD RANGE	LOWER FREQUENCY TRACKING POINT		HIGHER FREQUENCY TRACKING POINT		GEOMETRIC CENTRE TRACKING POINT
	FREQ.	ADJUST-MENT COIL	FREQ.	ADJUST-MENT TRIMMER	
8	21MHz	2L3/8	33MHz	2C23	26.3MHz
7	12MHz	2L3/7	21MHz	2C23	15.88MHz
6	7MHz	2L3/6	12MHz	2C23	9.2MHz
5	4MHz	2L3/5	7MHz	2C23	5.3MHz
4	1.85MHz	1L3/4	4.0MHz	1C23	2.7MHz
3	0.7MHz	1L3/3	1.65MHz	1C23	1.1MHz
2	300 kHz	1L3/2	700 kHz	1C23	460 kHz
1	130 kHz	1L3/1	300 kHz	1C23	195 kHz

'L3' ON
PCB legend

C23 ON
PCB legend

Table 2. RF and Mixer alignment points. (Frequencies as in Table 1).

HEAD RANGE	LOWER FREQUENCY TRACKING POINT		HIGHER FREQUENCY TRACKING POINT	
	ADJUSTMENT RF COIL	ADJUSTMENT MIXER COIL	ADJUSTMENT RF TRIMMER	ADJUSTMENT MIXER TRIMMER
8	2L1/8	2L2/8	2C5	2C13
7	2L1/7	2L2/7	2C5	2C13
6	2L1/6	2L2/6	2C5	2C13
5	2L1/5	2L2/5	2C5	2C13
4	1L1/4	2L2/4	1C5	1C13
3	1L1/3	2L2/3	1C5	1C13
2	1L1/2	2L2/2	1C5	1C13
1	1L1/1	2L2/1	1C5	1C13

'L1' ON
PCB legend

'L2' ON
PCB legend

C5 On
PCB legend

C13 ON
PCB legend

Aerial Amplifier

The only alignment required in this circuit stage is the adjustment of the whip aerial coils and trimmers. This is performed in a manner similar to alignment of the LF and HF Head RF and mixer coils (section (ii) of previous sub-section). The tracking points are specified (with appropriate adjustment components) in Table 3. An external sinewave generator should be used as the signal source and is fed to the Whip Aerial socket (UHF socket on receiver right hand side) via the dummy network illustrated below. The tracking of these coils is not too critical and therefore no check at the geometric mean is specified.

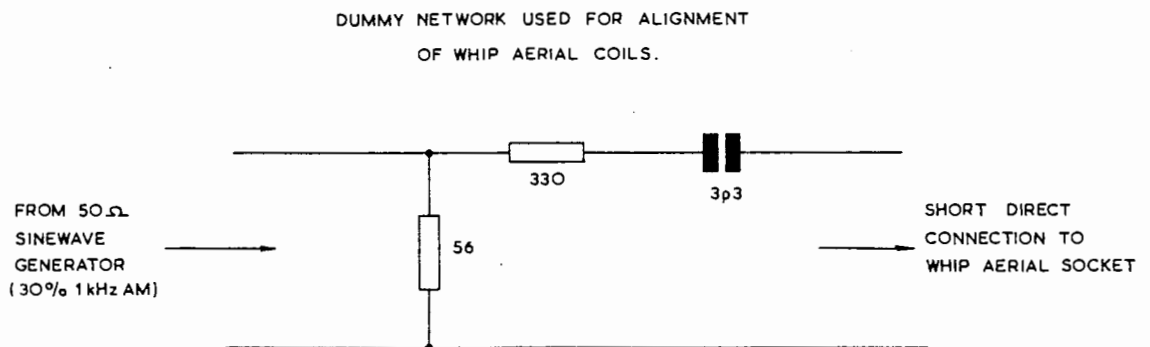

Table 3. Whip aerial coil alignment points.

HEAD RANGE	LOWER FREQUENCY TRACKING POINT		HIGHER FREQUENCY TRACKING POINT	
	FREQ.	ADJUSTMENT COIL	FREQ.	ADJUSTMENT COIL
8	22MHz	5L8	32MHz	5C8
7	13MHz	5L7	20MHz	5C7
6	7.5MHz	5L6	11.4MHz	5C6
5	4.2MHz	5L5	6.5MHz	5C5
4	2MHz	5L4	3.8MHz	5C4
3	0.9MHz	5L3	1.55MHz	5C3
2	320 kHz	5L2	630 kHz	5C2
1	140 kHz	5L1	270 kHz	5C1

prefix '5' not present
on PCB legend.

Rod Aerial (i.e. LOOP)

The only alignment required here is of the rod aerial coils and trimmers. This operation is performed in a manner similar to the alignment of the LF and HF Head RF and mixer coils (as described at sub-section (ii) above). The tracking points are specified (with appropriate adjustment components) in Table 4. An external sinewave should be used as a signal source and is fed to a small coil (refer to the illustration below) which is placed around the far end of the ferrite rod for the coil being adjusted. The coil inductance is varied by shifting the moveable coil carrier along the ferrite rod to give maximum output on the meter.

NOTE: care should be taken to establish that a distinct peak output point is found, as there is a natural tendency for the level to increase as the rod aerial coil is moved towards the coil which carries the input signal from the external generator. When the true alignment is found, the coil carrier is secured in place by a suitable method. The tracking of these coils is not too critical and no check of the geometric mean is specified.

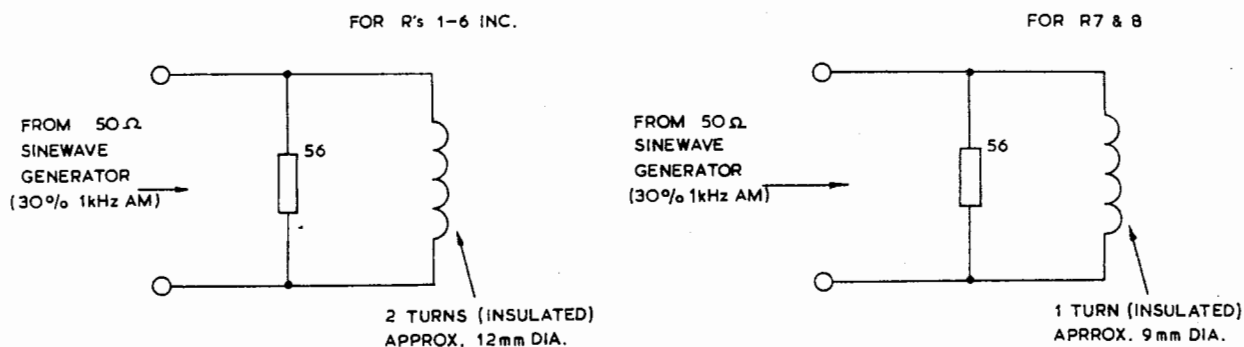

Table 4. Rod aerial coil alignment points.

HEAD RANGE	LOWER FREQUENCY TRACKING POINT		HIGHER FREQUENCY TRACKING POINT	
	FREQ.	ADJUSTMENT COIL	FREQ.	ADJUSTMENT TRIMMER
8	23MHz	6L8	30MHz	6C8
7	13MHz	6L7	19MHz	6C7
6	8MHz	6L6	11MHz	6C6
5	4.5MHz	6L5	6MHz	6C5
4	2MHz	6L4	3.5MHz	6C4
3	0.8MHz	6L3	1.4MHz	6C3
2	350 kHz	6L2	600 kHz	6C2
1	140 kHz	6L1	250 kHz	6C1

prefix '6' not present on PCB legend.

Mains Power Supply

CAUTION Care should be taken when conducting operating checks on this module as mains voltages are exposed when the module cover is removed.

No circuit stage adjustments have to be made to this module. The circuit diagram should be consulted for information concerning voltage levels etc. Changes to mains transformer primary tapping points are covered in Commissioning Notes, Book 1 (Page 2 and 3 of Section 2).

4) REMOVAL OF MODULES

- (i) In all cases the receiver will need to be removed from the cabinet by removal of the two screws located either side of each handle pivot; the securing screw, located on the cabinet bottom, and lifting the cabinet off the receiver. If the battery power supply is fitted, this must be removed first by releasing the two captive screws. As the supply is removed care should be taken to release the supply plug. Except when removing the 'Aerial amplifier', 'Rod aerial', or 'Rod aerial' modules, the top or bottom screen covers (as appropriate) will need to be removed.
- (ii) 'MAIN IF'. This pcb module is removed via the top of the receiver, though access is also required to the bottom. The two screws holding the PCB brackets to the centre support rail must be removed in addition to the single screw holding the pcb to the bottom pillar (below the crystal filter). The two pin polarised connector adjacent to the crystal filter should be disconnected and then the module can be carefully withdrawn, upwards from the socket mating with the 'Control Board'. Refitting is the reverse of this procedure taking great care to ensure that the pins on the 'MAIN IF' mates correctly (i.e. in correct position) with the socket in the 'Control Board'.
- (iii) 'CONTROL BOARD'. This module pcb is removed from below the receiver. The two screws holding the rear of the pcb to the centre support rail are removed; also remove the two screws holding the switch bracket frame to the front panel. The wiring to the front panel controls must be unsoldered, taking care to note the lead positions. The pcb is then gently pulled away from the receiver, releasing the connection with the 'MAIN IF' module. When the board is just clear of the multiway wiring loom connector (and the input lead coax connector released by slackening connector clamp screw situated on gang bottom support bracket) the board assembly is withdrawn. Refitting is simply the reverse of this procedure, taking care that the wiring loom connector and 'MAIN IF' connector mate in the correct position. When refitting the screws holding the switch bracket frame to the front panel, care should be taken to ensure that the push-buttons align accurately with the front panel apertures.
- (iv) 'LF and HF HEADS'. These simply unplug from below the receiver from the 'RF chassis PCB'. Care should be taken to ensure that components on adjacent Heads are not damaged when a particular Head is withdrawn. An extractor tool is supplied in the accessory pack to aid the operation (the tool mates with the hole at the top centre of each Head pcb).
- (v) 'AERIAL AMPLIFIER'. This is removed by first removing the four screws holding the pcb to the rear support frame, unsoldering the leads to the wafer switch, gang, feed-through and output coax-lead (noting the lead positioning ready for re-connection) and carefully withdrawing the pcb, backwards. Refitting is simply the reverse of this procedure.
- (vi) 'ROD AERIAL'. This is removed by first removing the four screws holding the pcb at each corner to a pillar, unsoldering the leads (balanced feeder) to the wafer switches (noting lead positions ready for re-connection) and carefully withdrawing the pcb backwards between the two rear support brackets. Refitting is simply the reverse of this procedure.

- (vii) 'RF CHASSIS AND RANGE SWITCH PCBS'. The total of seven pcbs form a jig-aligned permanent assembly; it is therefore recommended that if replacement is necessary, the unit is returned to the manufacturer. However, the whole assembly can be removed as follows:

The screws located in the coupler holding the 'Frequency Band' wafer switch shaft to the front clicker are slackened off and the shaft withdrawn via the rear of the receiver. All the HF and LF Heads must be removed as in section (iv) above, and also the six screws holding the RF chassis to the centre and rear support rails. The connections to the gang are input coax-leads which must be desoldered (noting lead positions ready for connection). The lead to the two-pin socket situated on the 'MAIN IF' should be disconnected at that module. The lead to the coax connector situated on the gang oscillator support bracket is removed with the PCB assembly (the connector is released by slackening the connector clamp screw. The pcb assembly can then be removed via the top of the receiver. Refitting is the reverse of this procedure, taking care, when replacing the switch shaft, that the wafers align correctly with respect to their switching sequence.

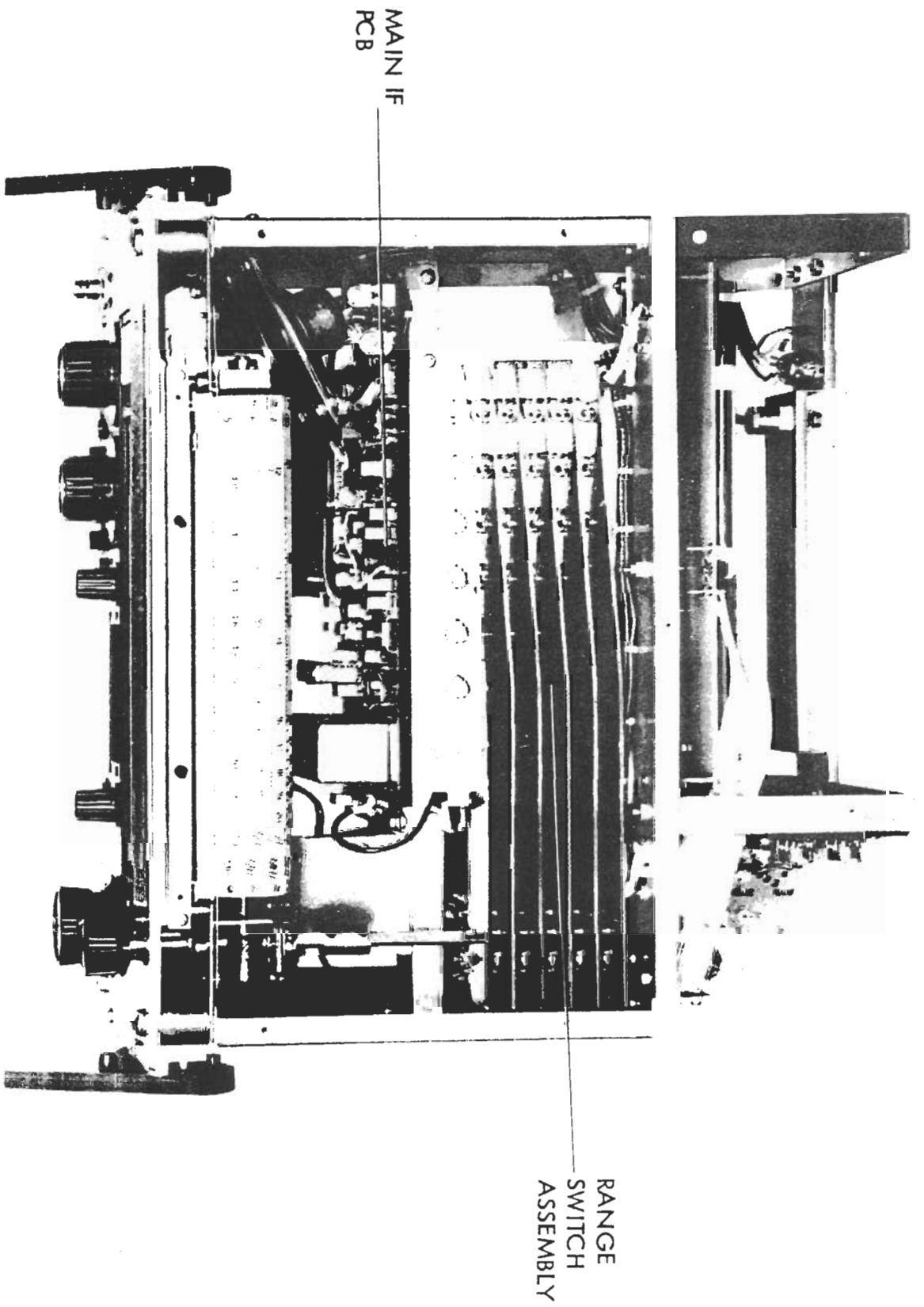

INTERNAL VIEW (TOP)

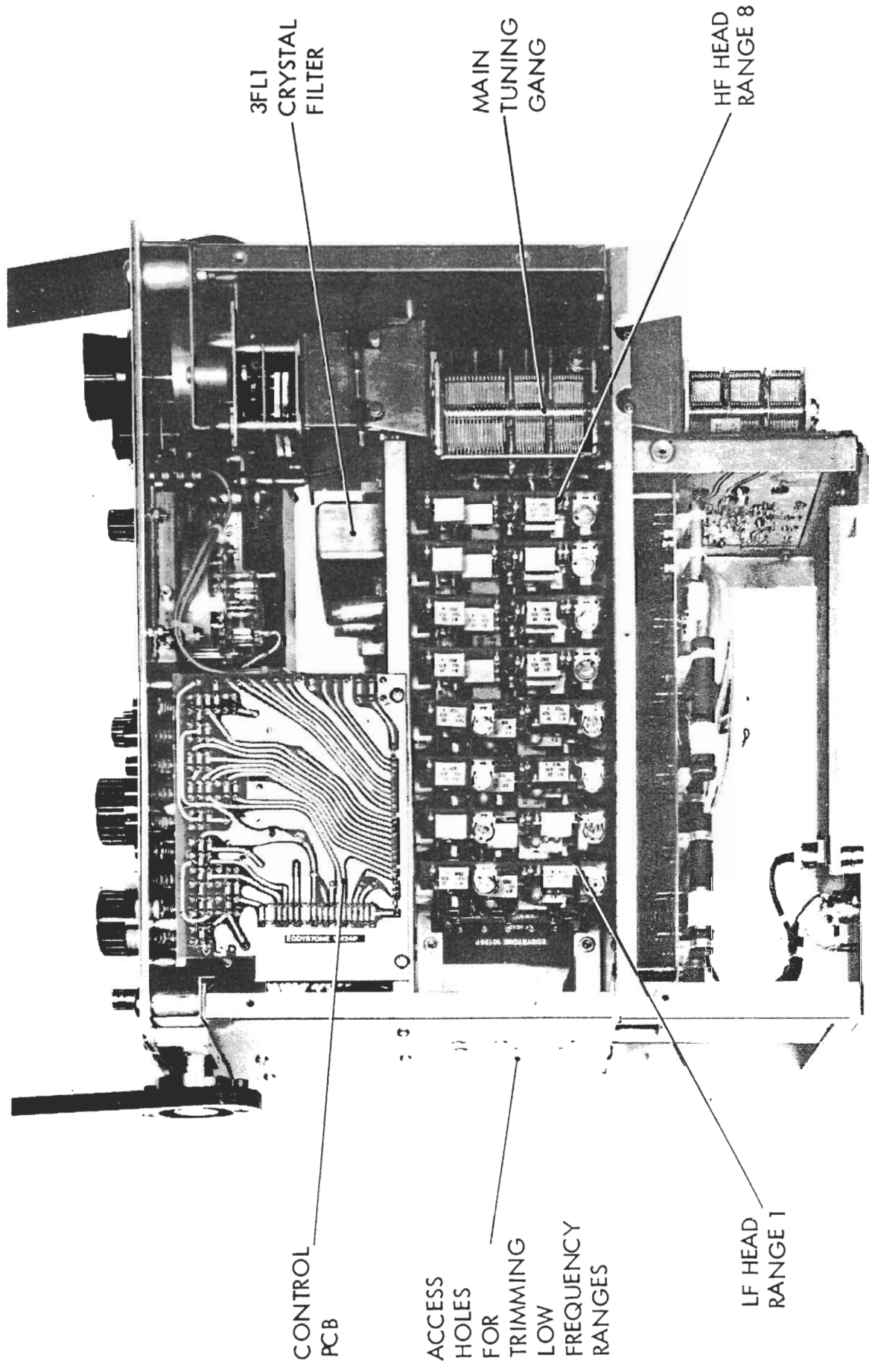

INTERNAL VIEW (BOTTOM)

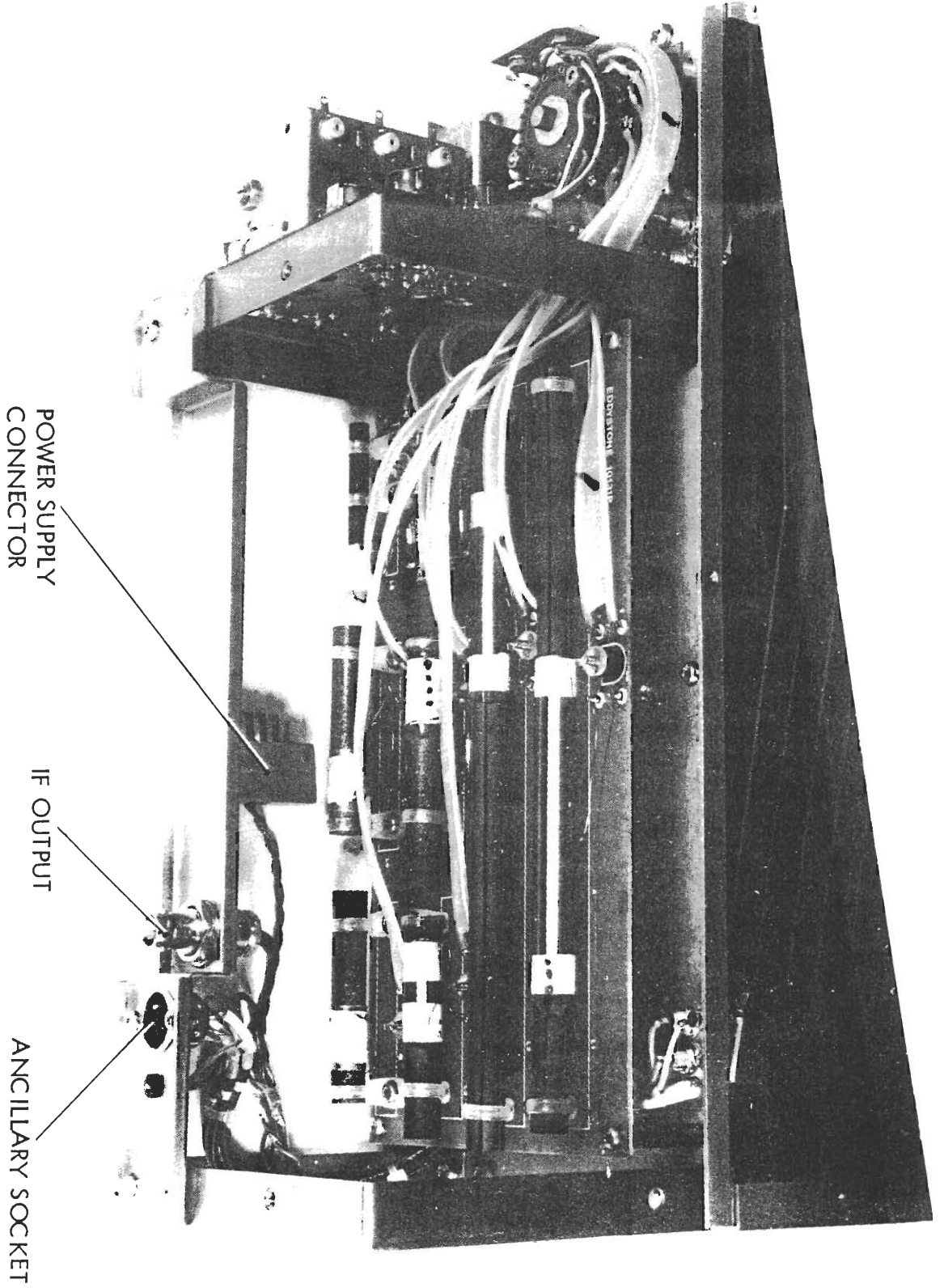

INTERNAL VIEW - ROD AERIALS

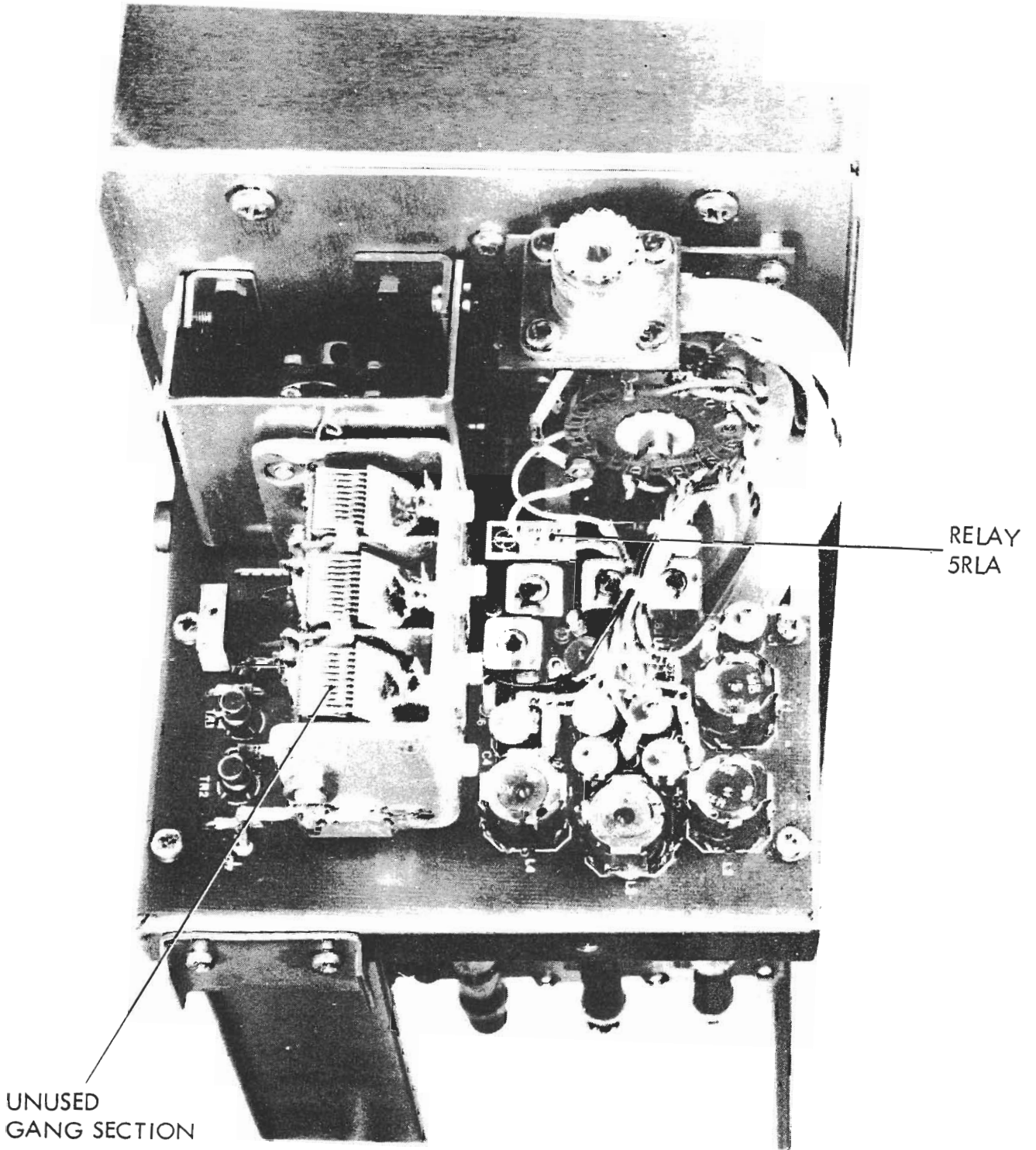

INTERNAL VIEW - AERIAL AMPLIFIER

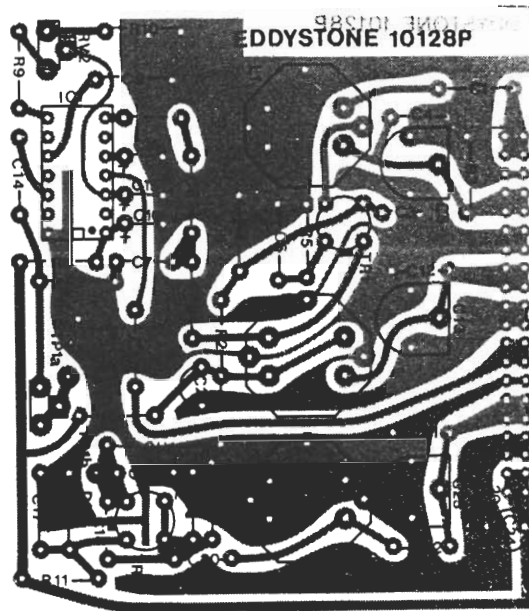

(1) LF HEAD

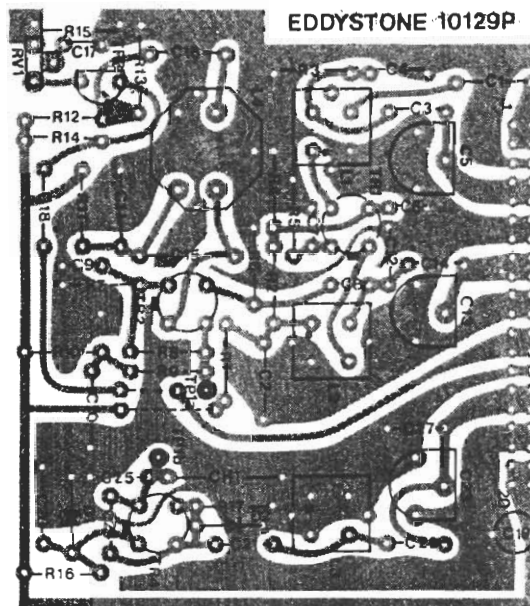

(2) HF HEAD

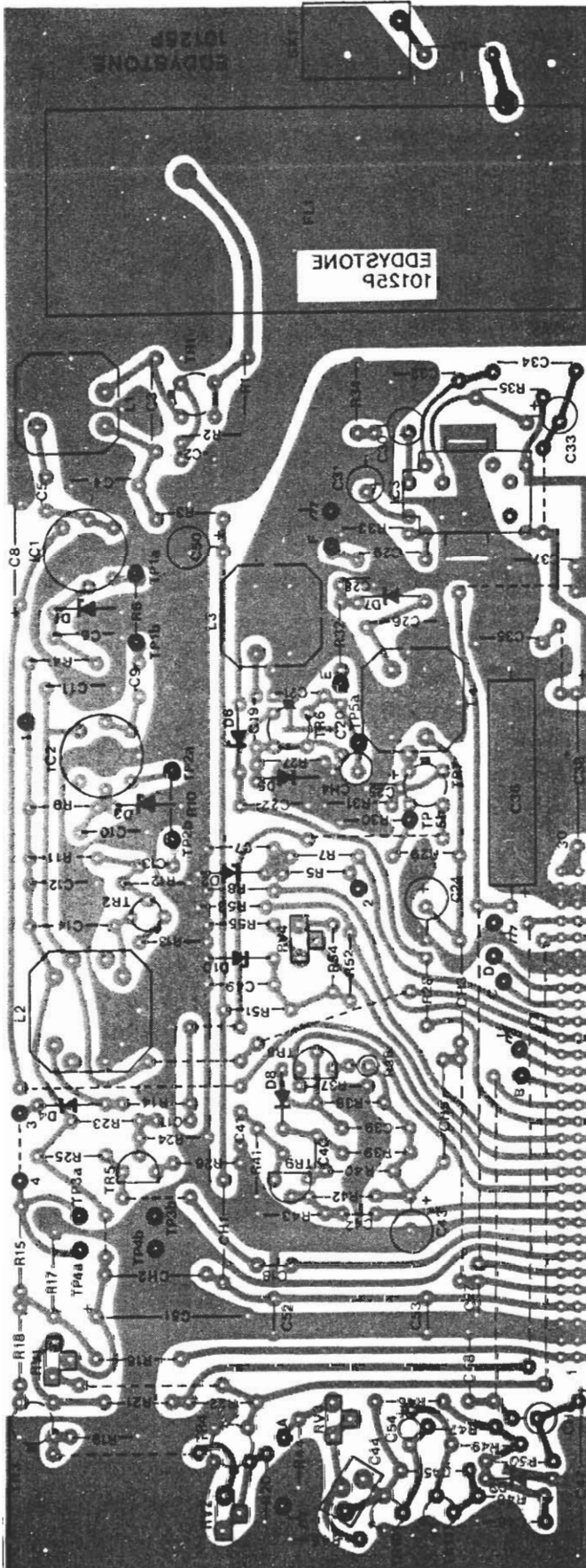

(3) MAIN IF

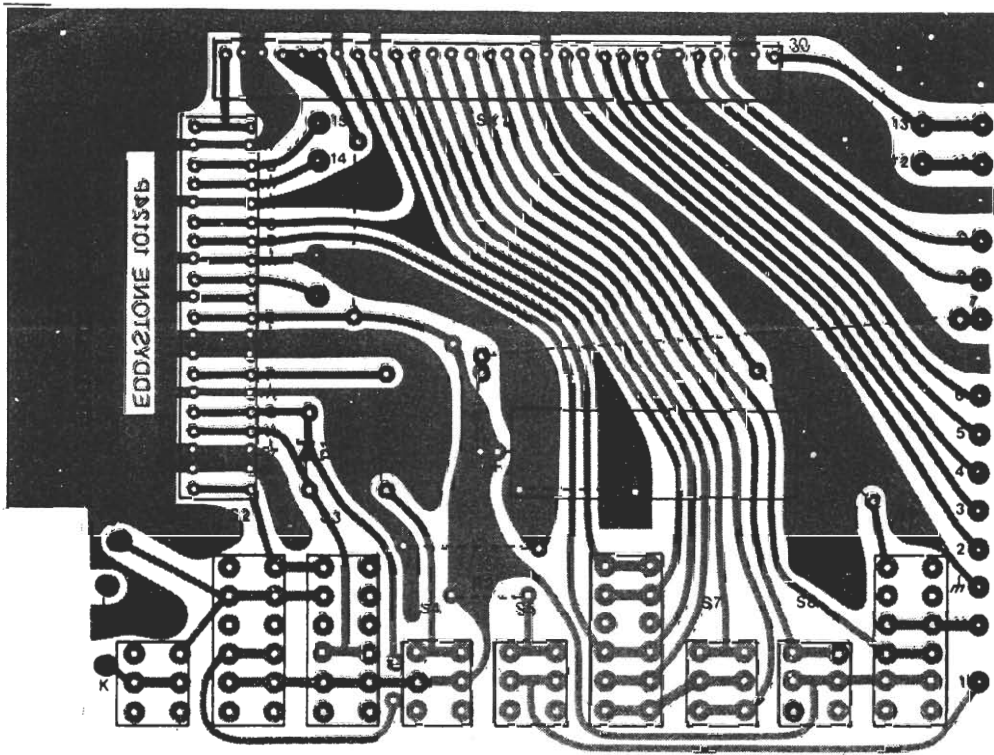

(4) CONTROL BOARD

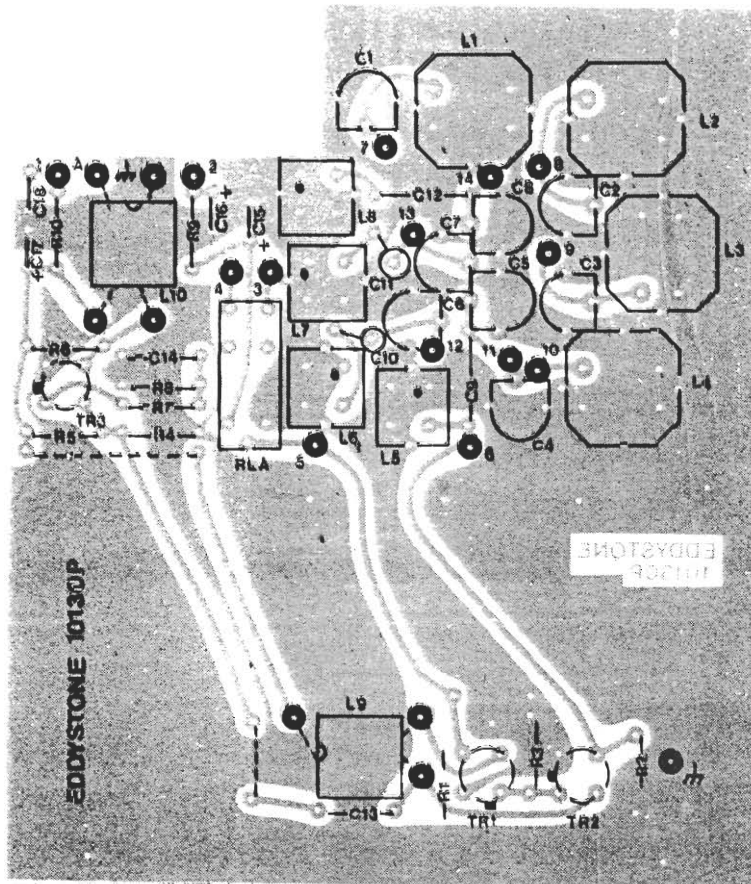

(5) AERIAL AMPLIFIER

10131P
EDDYSTONE

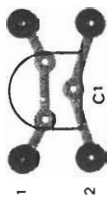

EDDYSTONE 10131P

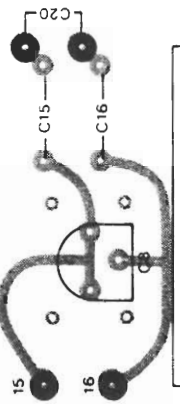
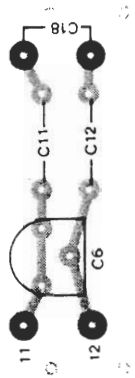
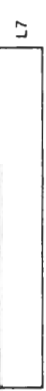
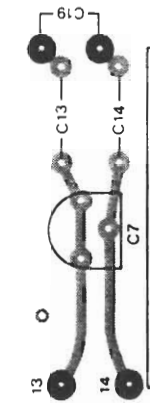
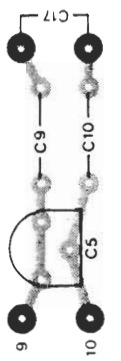

(6) ROD AERIAL BOARD

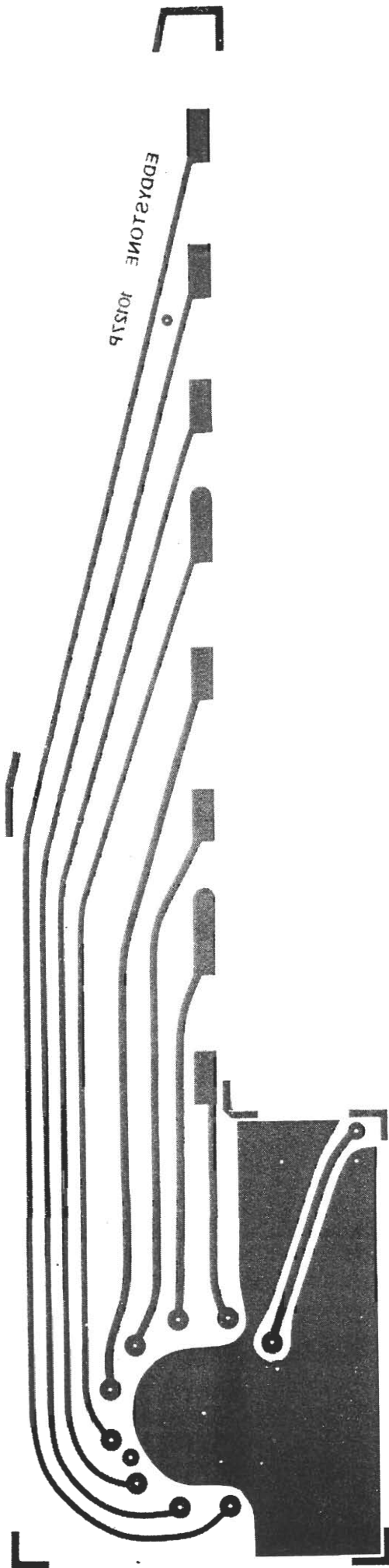

RANGE SWITCH BOARD

Section 6

COMPONENTS LIST

NOTES: SECTION FORMAT

1) MODULAR CONSTRUCTION

The individual reference number allocated to the various components which make up a particular circuit module will always start at "1" (e.g. R1, C1 etc).

Each component reference in the description which follows is prefixed by the particular Module reference number to facilitate the location of the component.

Each RF Range has its own RF amplifier/mixer/oscillator module which is selected, as required, to drive the IF circuitry in the "MAIN IF" module. The RF amplifier modules are termed "LF HEADS" on the four lowest frequency ranges (1-4) and "HF HEADS" on the four highest frequency ranges (5-8) making a total of 8 modules.

On each LF HEAD the majority of the components are identical - the same applying for each HF HEAD. Components which differ from range to range as well as having the module prefix have a suffix numerically equal to the range number on which they are fitted.

The overall coding is as follows:

Prefix	1	-	LF HEAD (suffixes /1 to /4)
	2	-	HF HEAD (suffixes /5 to /8)
	3	-	MAIN IF
	4	-	CONTROL BOARD
	5	-	AERIAL AMPLIFIER
	6	-	ROD AERIALS
	7	-	POWER SUPPLY
	8	-	MISCELLANEOUS-CHASSIS-RANGE SWITCHES.

EXAMPLES : 3RV1 : Potentiometer located in MAIN IF MODULE
2L2/6 : Inductance located in range 6 HF HEAD.

GUARANTEE

All 40A Series receivers are suitable for continuous use under normal operating conditions and should require very little routine maintenance over long periods of operation. With the exception of the semi-conductor devices, all components are guaranteed by the Manufacturer for a period of one year from the date of purchase. The semi-conductor devices are covered by a separate guarantee.

SERVICING

Spares for user servicing can be supplied and advice will be freely given when required. Any enquiries relating to service matters should be directed to the "Sales and Service Department", Eddystone Radio Limited, at our usual address. Please quote the equipment Model number and Serial Number in all communications. Should major servicing become necessary the unit can, by prior arrangement, be returned to the Manufacturer for attention; care should be taken to ensure that the unit is well protected against possible damage during transit.

Capacitors

Ref	Head	Value	Type	Tolerance	Wkg Voltage
1C 1	ALL	100n	Polycarbonate	20%	100V
1C 2	ALL	10 μ	Tantalum	+20%	16V
1C 3	ALL	10n	Disc Ceramic	+80%-20%	25V
1C 4	/1		NOT FITTED		
1C 4	/2		NOT FITTED		
1C 4	/3		NOT FITTED		
1C 4	/4	18p	Polystyrene	1%	160V
1C 5	ALL	2-30p	Trimmer		
1C 6	ALL	100n	Polycarbonate	20%	100V
1C 7	ALL	100p	Polystyrene	2%	160V
1C 8	ALL	100n	Polycarbonate	20%	100V
1C 9	ALL	100n	Polycarbonate	20%	100V
1C10	ALL	10 μ	Tantalum	+20%	16V
1C11	ALL	100n	Polycarbonate	-20%	100V
1C12	/1		NOT FITTED		
1C12	/2		NOT FITTED		
1C12	/3		NOT FITTED		
1C12	/4	18p	Polystyrene	1%	160V
1C13	ALL	2-30p	Trimmer		
1C14	ALL	100n	Polycarbonate	20%	100V
1C15	ALL	1 μ	Tantalum	+20%	35V
1C16	ALL	1 μ	Tantalum	+20%	35V
1C17	ALL	100n	Polycarbonate	-20%	10V
1C18	ALL	150p	Polystyrene	2%	160V
1C19	ALL	150p	Polystyrene	2%	160V
1C20	/1	120p	Polystyrene	2%	160V
1C20	/2	220p	Polystyrene	2%	160V
1C20	/3	33p	Polystyrene	1%	160V
1C20	/4	82p	Polystyrene	2%	160V
1C21	/1		NOT FITTED		
1C21	/2	15p	Polystyrene	+1%	160V
1C21	/3		NOT FITTED		
1C21	/4		NOT FITTED		

Capacitors continued...

Ref	Head	Value	Type	Tolerance	Wkg Voltage
1C22	/1	100p	Polystyrene	2%	160V
		10p	Polystyrene	+1%	160V
1C22	/2	68p	Polystyrene	-2%	160V
1C22	/3	180p	Polystyrene	2%	160V
		10p	Polystyrene	+1%	160V
1C22	/4	470p	Polystyrene	-1%	160V
		18p	Polystyrene	1%	160V
1C23	ALL	2-30p	Trimmer		
1C24	ALL	10μ	Tantalum	+20%	16V
2C 1	ALL	100n	Polycarbonate	20%	100V
2C 2	ALL	100n	Polycarbonate	20%	100V
2C 3	/5	1000p	Polystyrene	2%	63V
2C 3	/6	390p	Polystyrene	2%	160V
		120p	Polystyrene	2%	160V
2C 3	/7	470p	Polystyrene	2%	160V
2C 3	/8	180p	Polystyrene	2%	160V
		22p	Polystyrene	2%	160V
2C 4	/5	39p	Polystyrene	2%	160V
2C 4	/6	27p	Polystyrene	2%	160V
2C 4	/7	27p	Polystyrene	2%	160V
2C 4	/8	22p	Polystyrene	2%	160V
2C 5	ALL	2-30p	Trimmer		
2C 6	ALL	10n	Disc Ceramic	+80%-20%	25V
2C 7	ALL	10n	Disc Ceramic	+80%-20%	25V
2C 8	ALL	10n	Disc Ceramic	+80%-20%	25V
2C 9	ALL	10n	Disc Ceramic	+80%-20%	25V
2C10	ALL	100n	Polycarbonate	20%	100V
2C11	ALL	100n	Polycarbonate	20%	100V
2C12	/5	39p	Polystyrene	2%	160V
2C12	/6	27p	Polystyrene	2%	160V
2C12	/7	22p	Polystyrene	2%	160V
2C12	/8	15p	Polystyrene	+1p	160V
2C13	ALL	2-30p	Trimmer		
2C14	/5	1000p	Polystyrene	2%	63V
2C14	/6	390p	Polystyrene	2%	160V
		120p	Polystyrene	2%	160V
2C14	/7	470p	Polystyrene	2%	160V
2C14	/8	180p	Polystyrene	2%	160V
		22p	Polystyrene	2%	160V
2C15	ALL	2000p	Polystyrene	2%	63V
2C16	ALL	100n	Polycarbonate	20%	100V
2C17	ALL	10n	Disc Ceramic	+80%-20%	25V
2C18	ALL	100n	Polycarbonate	20%	100V
2C19	ALL	10μ	Tantalum	+20%	16V
2C20	ALL	100n	Polycarbonate	20%	100V
2C21	ALL	10n	Disc Ceramic	+80%-20%	25V
2C22	/5	470p	Polystyrene	2%	160V

Capacitors continued....

Ref	Head	Value	Type	Tolerance	Wkg Voltage
2C22	/6	270p	Polystyrene	2%	160V
		82p	Polystyrene	2%	160V
2C22	/7	180p	Polystyrene	2%	160V
		180p	Polystyrene	2%	160V
2C22	/8	150p	Polystyrene	2%	160V
		22p	Polystyrene	2%	160V
2C23	ALL	2-30p	Trimmer		
2C24	/5	82p	Polystyrene	2%	160V
2C24	/6	56p	Polystyrene	2%	160V
2C24	/7	39p	Polystyrene	2%	160V
2C24	/8	22p	Polystyrene	2%	160V
2C25	/5	82p	Polystyrene	2%	160V
2C25	/6	56p	Polystyrene	2%	160V
2C25	/7	39p	Polystyrene	2%	160V
2C25	/8	22p	Polystyrene	2%	160V
2C26	ALL	100p	Polystyrene	2%	160V
2C27	/5	10p	Polystyrene	+1p	160V
2C27	/6		NOT FITTED		
2C27	/7	10p	Polystyrene	+1p	160V
2C27	/8	10p	Polystyrene	+1p	160V
3C 1		100n	Polycarbonate	20%	100V
3C 2		10n	Disc Ceramic	+80%-20%	25V
3C 3		820p	Polystyrene	2%	63V
		15p	Polystyrene	5%	63V
3C 4		100n	Polycarbonate	20%	100V
3C 5		10n	Disc Ceramic	+80%-20%	25V
3C 6		100n	Polycarbonate	20%	100V
3C 7		100n	Polycarbonate	20%	100V
3C 8		47μ	Electrolytic	+50%-10%	10V
3C 9		10n	Disc Ceramic	+80%-20%	25V
3C10		100n	Polycarbonate	20%	100V
3C11		100n	Polycarbonate	20%	100V
3C12		100n	Polycarbonate	20%	100V
3C13		10n	Disc Ceramic	+80%-20%	25V
3C14		470p	Polystyrene	2%	63V
3C15		2n-10n	Polycarbonate		S. O. T.
3C16		2200p	Silvered Mica	2%	S. O. T.
		4700p	Silvered Mica	2%	S. O. T.
3C17		10n	Disc Ceramic	+80%-20%	25V
3C18		10n	Disc Ceramic	+80%-20%	25V
3C19		47p	Polystyrene	2%	63V
3C20		220p	Polystyrene	2%	63V
3C21		220p	Polystyrene	2%	63V
3C22		100n	Polycarbonate	20%	100V
3C23		22p	Polystyrene	1%	63V
3C24			NOT FITTED		
3C25		3μ3	Tantalum	+20%	16V
3C26		330p	Polystyrene	2%	63V

Capacitors continued.....

Ref	Value	Type	Tolerance	Wkg Voltage
3C27	10n	Disc Ceramic	+80%-20%	25V
3C28	1000p	Disc Ceramic	+80%-20%	25V
3C29	100n	Polycarbonate	20%	100V
3C30	150μ	Electrolytic (single ended)	+50%-10%	16V
3C31	100μ	Electrolytic	+50%-10%	10V
3C32	10n	Disc Ceramic	+80%-20%	25V
3C33	150μ	Electrolytic (single ended)	+50%-10%	16V
3C34	1800p	Polystyrene	2%	63V
3C35	220n	Polycarbonate	20%	100V
3C36	680μ	Electrolytic	+50%-10%	16V
3C37	100n	Polycarbonate	20%	100V
3C38	150μ	Electrolytic	+50%-10%	16V
3C39	100n	Polycarbonate	20%	100V
3C40	10n	Disc Ceramic	+80%-20%	25V
3C41	10n	Disc Ceramic	+80%-20%	25V
3C42	10n	Disc Ceramic	+80%-20%	25V
3C43	68μ	Electrolytic (single ended)	+50%-10%	16V
3C44	6-30p	Trimmer		
3C45	100n	Polycarbonate	20%	100V
3C46	100n	Polycarbonate	20%	100V
3C47	68μ	Electrolytic	+50%-10%	16V
3C48	100n	Polycarbonate	20%	100V
3C49	100n	Polycarbonate	20%	100V
3C50	68μ	Electrolytic (single ended)	+50%-10%	16V
3C51	68μ	Electrolytic (single ended)	+50%-10%	16V
3C52	10n	Disc Ceramic	+80%-20%	25V
3C53	10n	Disc Ceramic	+80%-20%	25V
3C54	3μ3	Tantalum	+20%	16V
4C 1	2200μ	Fixed Electrolytic	+80%-20%	10V
5C 1	4-30p	Trimmmers Horizontal		
5C 2	4-30p	Trimmmers Horizontal		
5C 3	4-30p	Trimmmers Horizontal		
5C 4	4-30p	Trimmmers Horizontal		
5C 5	4-30p	Trimmmers Horizontal		
5C 6	4-30p	Trimmmers Horizontal		
5C 7	4-30p	Trimmmers Horizontal		
5C 8	4-30p	Trimmmers Horizontal		
5C 9	1000p	Polystyrene	2%	63V
5C10	330p	Polystyrene	2%	160V
	180p	Polystyrene	2%	160V
5C11	470p	Polystyrene	2%	160V
5C12	200p	Polystyrene	2%	160V
5C13	100n	Polycarbonate	20%	100V
5C14	100n	Polycarbonate	20%	100V
5C15	1μ	Tantalum	+20%	35V
5C16	1μ	Tantalum	+20%	35V
5C17	1μ	Tantalum	+20%	35V

Capacitors continued....

Ref	Value	Type	Tolerance	Wkg Voltage
5C18	10n	Disc Ceramic	+80%-20%	25V
5C19	18p	Polystyrene	2%	160V
5C20	33p	Polystyrene	10%	160V
5C21	27p	Polystyrene	2%	160V
5C22	27p	Polystyrene	2%	160V
5C23	39p	Polystyrene	2%	160V
6C 1	4-30p	Trimmers Horizontal		
6C 2	4-30p	Trimmers Horizontal		
6C 3	4-30p	Trimmers Horizontal		
6C 4	4-30p	Trimmers Horizontal		
6C 5	4-30p	Trimmers Horizontal		
6C 6	4-30p	Trimmers Horizontal		
6C 7	4-30p	Trimmers Horizontal		
6C 8	4-30p	Trimmers Horizontal		
6C 9	1000p	Polystyrene	2%	63V
6C10	1000p	Polystyrene	2%	63V
6C11	330p	Polystyrene	2%	63V
	180p	Polystyrene	2%	63V
6C12	330p	Polystyrene	2%	63V
	180p	Polystyrene	2%	63V
6C13	470p	Polystyrene	2%	160V
6C14	470p	Polystyrene	2%	160V
6C15	200p	Polystyrene	2%	160V
6C16	200p	Polystyrene	2%	160V
6C17	10p	Polystyrene	+1p	160V
6C18	10p	Polystyrene	+1p	160V
6C19	10p	Polystyrene	+1p	160V
6C20	33p	Polystyrene	-2%	125V
7C 1	2n2	Disc Ceramic	Class Y	250V
7C 2	2n2	Disc Ceramic	Class Y	250V
7C 3	68n	P. E. T. P.	Class X	250V AC
7C 4	1000μ	Electrolytic	+80%-20%	25V
7C 5	100n	Polycarbonate	20%	100V
7C 6	22μ	Tantalum	+20%	16V
8C 1	220μ	Electrolytic	+50%-10%	10V
8C 2	22p	Polystyrene	10%	160V
8C 3	470n	Polycarbonate	20%	100V

Resistors

All resistors are 5% tolerance 0.3W rating CR25 unless otherwise stated.

Ref	Head	Value Ohms	Rating W
1R 1	ALL	180	
1R 2	ALL	39K	
1R 3	/1	Not Fitted	
1R 3	/2	22K	
1R 3	/3	15K	
1R 4	ALL	22K	
1R 5	ALL	220	
1R 6	ALL	1K	
1R 7	ALL	1K	
1R 8	ALL	220	
1R 9	ALL	2K2	
1R10	ALL	8K2	
1R11	ALL	680	
1R12	ALL	22K	
1R13	/1	22K S.O.T.	
1R13	/2	22K S.O.T.	
1R13	/3	22K S.O.T.	
1R13	/4	22K S.O.T.	
2R 1	ALL	180	
2R 2	ALL	39K	
2R 3	/5	Not Fitted	
2R 3	/6	Not Fitted	
2R 3	/7	Not Fitted	
2R 4	ALL	22K	
2R 5	ALL	220	
2R 6	ALL	100K	
2R 7	ALL	220	
2R 8	ALL	12K	
2R 9	ALL	150	
2R10	ALL	180	
2R11	ALL	180	
2R12	ALL	18K	
2R13	ALL	15K	
2R14	ALL	150	
2R15	ALL	1K	
2R16	ALL	680	
2R17	ALL	22K	
3R 1		150	
3R 2		220	
3R 3		180	
3R 4		220	
3R 5		220	
3R 6		220	
3R 7		1K2	
3R 8		1K2	
3R 9		220	

Ref	Value Ohms	Rating W
3R10	10	
3R11	6K8	
3R12	680	
3R13	18	
3R14	100K	
	10K	
3R15	6M8 VR37	
3R16	4M7 VR37	
3R17	6M8 VR37	
3R18	3M9 VR37	
3R19	1K	
3R20	1K	
3R21	3K3	
3R22	1K5	
3R23	120K	
3R24	100K	
3R25	680	
3R26	560	
3R27	22K	
3R28	680	
3R29	39K	
3R30	22K	
3R31	220	
3R32	22K	
3R33	22K	
3R34	18	
3R35	100	
3R36	1K2	
3R37	82K	
3R38	100K	
3R39	33K	
3R40	4K7	
3R41	3K9	
3R42	10K	
3R43	4K7	
3R44	56	
3R45	82	
3R46	10K	
3R47	4K7	
3R48	33K	
3R49	1K	
3R50	220	
3R51	220	
3R52	2K2	
3R53	3K3	
3R54	1K	
3R55	3K3	

Ref	Value Ohms	Rating W
4R 1	120K	
4R 2	120K	
5R 1	330K	
5R 2	330K	
5R 3	820	
5R 4	6K8	
5R 5	47K	

Ref	Value Ohms	Rating W
5R 6	1K2	
5R 7		
5R 8	120	
5R 9	100	
5R10	100	
6R 1	100K S.O.T.	
6R 2	27K S.O.T.	

Potentiometers

Ref	Value	Law	Type	Function
1RV 1	10K	Lin.)	Pre-set	
1RV 2	10K	Lin.)		
)		
2RV 1	100K)		
)		
3RV 1	2K2)		
3RV 2	2K2)		
3RV 3	2K2)		
3RV 4	1K)		

Diodes

Ref	Type	Manufacturer
1D 1	BZX79C6V2 (Zener)	Mullard
1D 2	BAX13	Mullard
2D 1	BZX77C6V2 (Zener)	Mullard
2D 2	BAX13	Mullard
3D 1	BZY88C5V6 (Zener)	Mullard
3D 2	BZY88C5V6 (Zener)	Mullard
3D 3	BZY88C5V6 (Zener)	Mullard
3D 4	IN916	Mullard
3D 5	BAX13	Mullard
3D 6	BZY88C5V6 (Zener)	Mullard
3D 7	OA47	Mullard
3D 8	BAX13	Mullard
3D 9	BZY88C5V6 (Zener)	Mullard
3D10	BZY88C5V6 (Zener)	Mullard

Diodes continued.....

Ref	Type	Manufacturer
4D 1	IN4004	Motorola
7D 1	IN4004	Motorola
7D 2	IN4004	Motorola
7D 3	IN4004	Motorola
7D 4	IN4004	Motorola

Transistors

Ref	Type	Manufacturer
1TR 1	40673	
1TR 2	40673	
2TR 1	40673	
2TR 2	40673	
2TR 3	BC547B	Mullard
2TR 4	40673	
3TR 1	40673	Mullard
3TR 2	BC107B	
3TR 3	UC734B	Union Carbide
3TR 4	UC734B	Union Carbide
3TR 5	BC547B	Mullard
3TR 6	40673	Mullard
3TR 7	40673	
3TR 8	BC560B or BC214B	
3TR 9	BC547B	
3TR10	2N2369A	
3TR11	2N2369A	
5TR 1	UC734B	Union Carbide
5TR 2	UC734B	Union Carbide
5TR 3	BFX89	Mullard

Integrated Circuits

Ref	Type	Manufacturer
1IC 1	3402	
3IC 1	SL612	Plessey
3IC 2	SL612	Plessey
3IC 3	TBA 810S	SGS
7IC 1	MC7808CP	Motorola

Inductors

Ref	Description	Type	Manufacturer
1L 1	RF Coil	D5232	
1L 2	Mixer	D5233	
1L 3	Oscillator	D5234	
3L 1	Input Coil, IF	D5274	
3L 2	Output Coil, IF	D5275	
3L 3	BFO Coil	D5277	
3L 4	Detector Coil	D5276	
5L 1	Range 1 Aerial	D5257	
5L 2	2 Aerial	D5258	
5L 3	3 Aerial	D5259	
5L 4	4 Aerial	D5260A	
5L 5	5 Aerial	D5261	
5L 6	6 Aerial	D5262	
5L 7	7 Aerial	D5263	
5L 8	8 Aerial	D5264	
5L 9	Input Broadband	D5265	
5L10	Output Broadband	D5278	
6L 1		D5266	
6L 2		D5267	
6L 3		D5268	
6L 4		D5269	
6L 5		D5270	
6L 6		D5271	
6L 7		D5272	
6L 8		D5273	
7L 1		D5279	

Chokes

Ref	Description	Type	Manufacturer
1CH 1 /1	1mH	SC60	Sigma
1CH 1 /2	470 μ H	SC60	Sigma
1CH 1 /3	470 μ H	SC60	Sigma
1CH 1 /4	470 μ H	SC60	Sigma
2CH 1 /5	1mH	SC60	Sigma
2CH 1 /6	1mH	SC60	Sigma
2CH 1 /7	100 μ H	SC60	Sigma
2CH 1 /8	47 μ H	SC60	Sigma

Major Spares continued....

Ref	Description	Part No.
<u>SWITCHES continued:-</u>		
4S2	Loop))	
4S3	Whip) 4 Button Ganged)	10231P
4S6	AGC) Push Switch)	
4S9	CAL) Assembly)	
4S5	Illumination	10233P
7S1	Mains On-Off	7352P
8S1	Range Switch Assembly:- Switch PCB Assembly S1A-F Wafer Assembly S1G-H Wafer Assembly	LP3616/4 10227P 10343P
8S2	CISPR - CHECK BATT - LONG	8828P
<u>TRIMMER CAPACITORS :-</u>		
1C5/1 to /5))	
1C13))	
1C23) All 2-30P)	
2C5) 100V Foil)	8735P
2C13) Type 107/3901/027)	
2C23))	
3C44	6-30p 7S-TRIKO 160V Ceramic	7289P
5C1 to 5C8) All 2-30p 100V Foil)	8735P
6C1 to 6C8) Type 107/3901/027)	
<u>POTENTIOMETERS :-</u>		
8RV1	SET CAL 10K LOG CARBON	10579P
8RV2	AF GAIN 1K LIN CARBON	10580P
<u>CRYSTAL FILTER :-</u>		
3FL1	Xtal Filter F202	10582P

Major Spares continued.....

Ref	Description	Part No.
<u>TUNING GANG CONDENSERS:-</u>		
8C3	16.5p - 362.5p)	7757P
8C4	13.5p - 359.5p) 3-GANGED	
8C5	13.5p - 359.5p)	
8C6))	6528P
8C7)	13.5p - 365p) 3-GANGED	
8C8)	8C8 NOT USED)	
<u>ATTENUATORS:-</u>		
"dB μ V"	X1 Type RA50 (1dB STEPS)	10113P
"dB μ V"	X10 Type RA51 (10dB STEPS)	10112P
<u>PLUGS & SOCKETS:-</u>		
5-pin DIN Plug 240°		10230P
Coax Plug		9421P
4-Way Socket (MAINS/BATT)		D3406
BNC Connector (2 sockets)		7225P
Phone-Jack Socket		6660P
Coax Socket		9420P
RF Connector		10228P
<u>MISCELLANEOUS:-</u>		
Loudspeaker		8567P
Panel Meter		10210P
Handle Assembly		D5333P
Control Knobs (Black)		10621P
Control Knob Caps		9389P
2 Nut Covers		10622P
3 Fuse Holders		9458P
1 Box Spanner		9057P
1 Extractor Tool (PCBs)		10237P
1 Trimming Tool (T.T.1)		8451P
1 Trimming Tool		8333P
Dial Lamp Bulbs (2 off) 6 Volt		10236P
Relay 95RL1) RH6V		10583P
Mains Transformer (7T1) Type 9100		10581P

LF HEAD 1

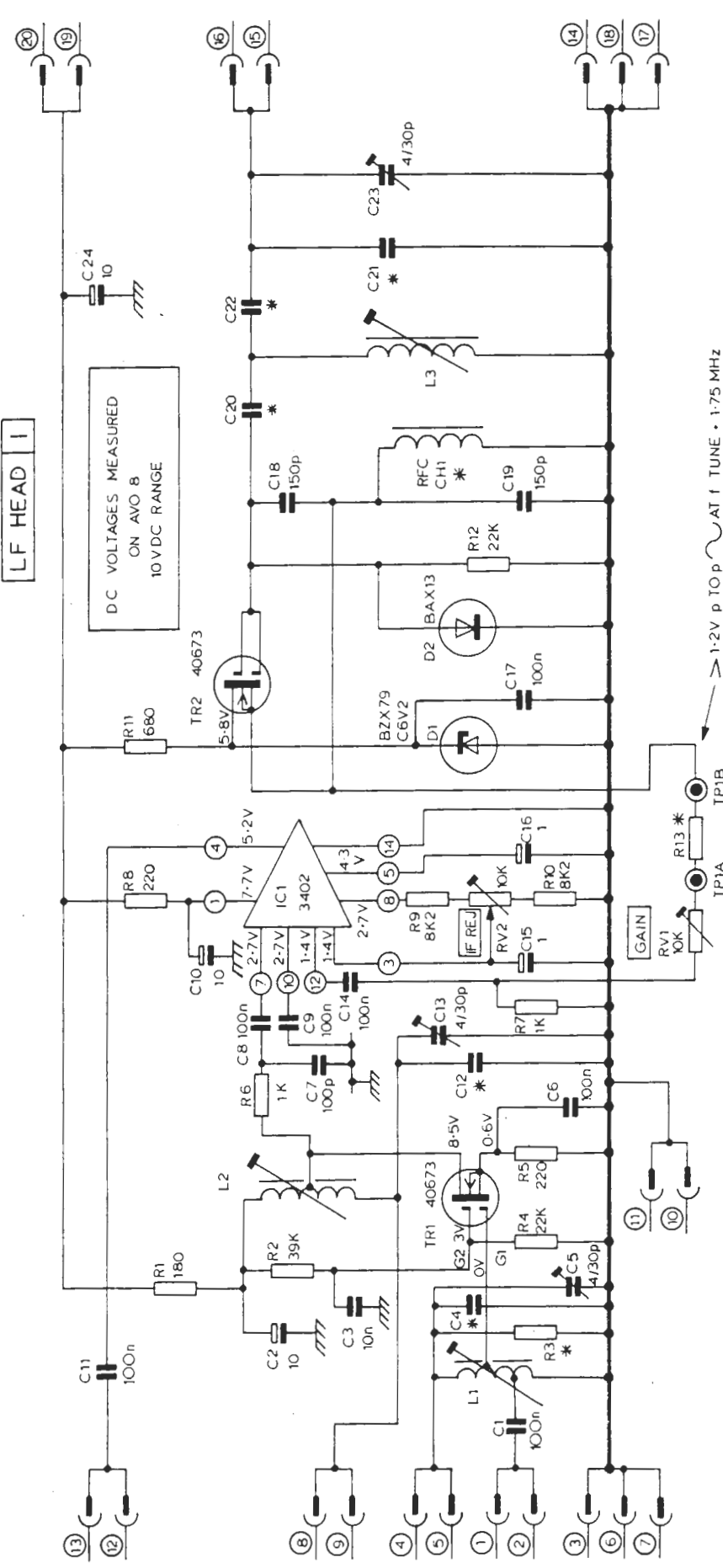

LF HEAD	R3	VALUE	R13	VALUE	C4	VALUE	C12	VALUE	C20	VALUE	C21	VALUE	C22	VALUE	CH1	VALUE	COVERAGE	MHZ	
ONE	/1	NOT FITTED	/1	22K	/1	NOT FITTED	/1	NOT FITTED	/1	220p	/1	220p	/1	15p	/1	68p	/1	1mH	0.13 — 0.3
TWO	/2	10K	/2	22K	/2	NOT FITTED	/2	NOT FITTED	/2	120p	/2	120p	/2	NOT FITTED	/2	100p // 10p	/2	470µH	0.3 — 0.7
THREE	/3	22K	/3	1K8	/3	NOT FITTED	/3	NOT FITTED	/3	33p	/3	33p	/3	NOT FITTED	/3	180p // 10p	/3	470µH	0.7 — 1.65
FOUR	/4	15K	/4	1K8	/4	18p	/4	18p	/4	82p	/4	82p	/4	NOT FITTED	/4	470p // 18p	/4	470µH	1.85 — 4.0

*

H F HEAD 2

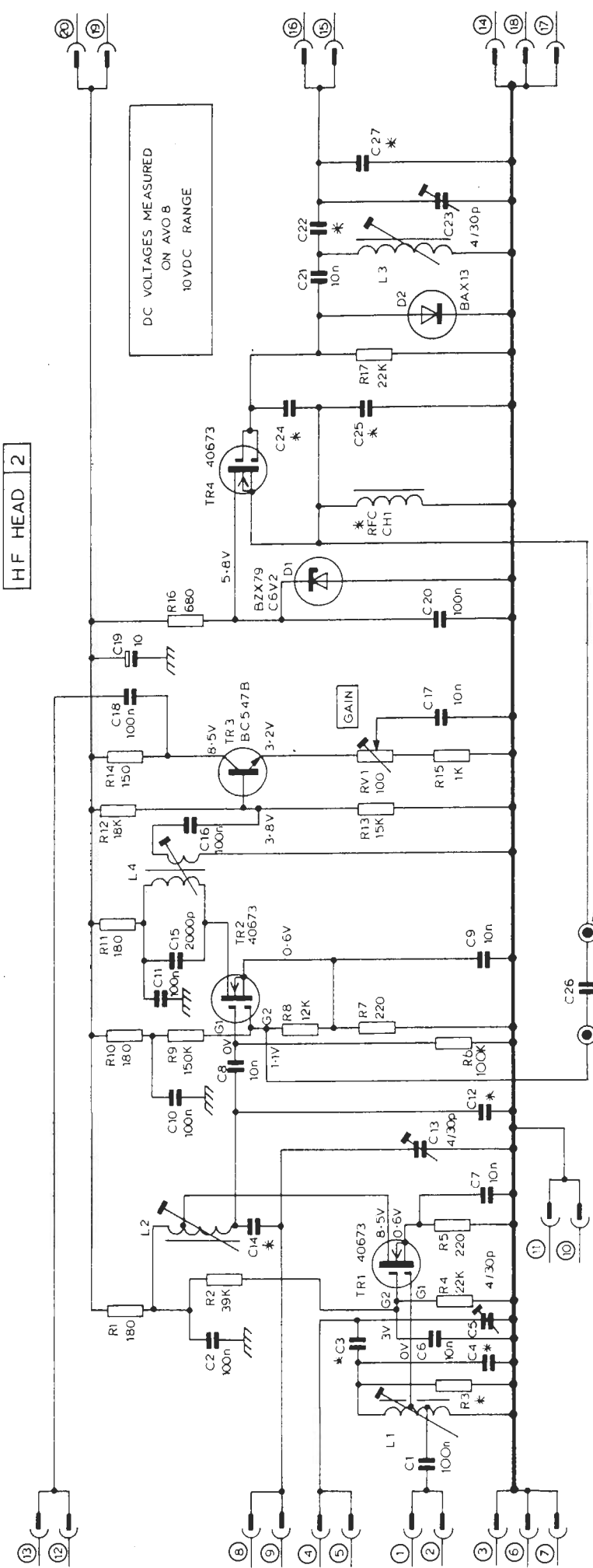

TP1A 100p TP1B \sim 1.2V p10p \sim AT 1 TUNE • 1.75 MHz

HF HEAD	R3	VALUE	C3	VALUE	C4	VALUE	C12	VALUE	C14	VALUE	C22	VALUE	C24/25	VALUE	C27	VALUE	CH1	DESIGNATION	COVERAGE	MHz
FIVE	/5	NOT FITTED	/5	1000p	/5	39p	/5	39p	/5	1000p	/5	470p	/5	82p	/5	10p	/5	1mH	3-9	7-1
SIX	/6	NOT FITTED	/6	390p//120p	/6	27p	/6	27p	/6	390p//120p	/6	270p//82p	/6	56p	/6	NOT FITTED	/6	1mH	6-9	12-1
SEVEN	/7	NOT FITTED	/7	470p	/7	27p	/7	22p	/7	470p	/7	180p//180p	/7	39p	/7	10p	/7	100μH	11-8	21-2
EIGHT	/8	NOT FITTED	/8	180p//22p	/8	22p	/8	15p	/8	180p//22p	/8	150p//22p	/8	22p	/8	10p	/8	47μH	20-8	32-2

*

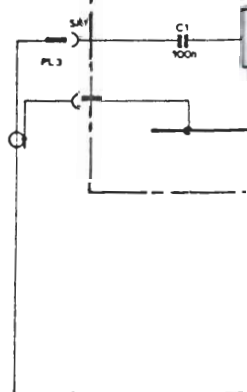
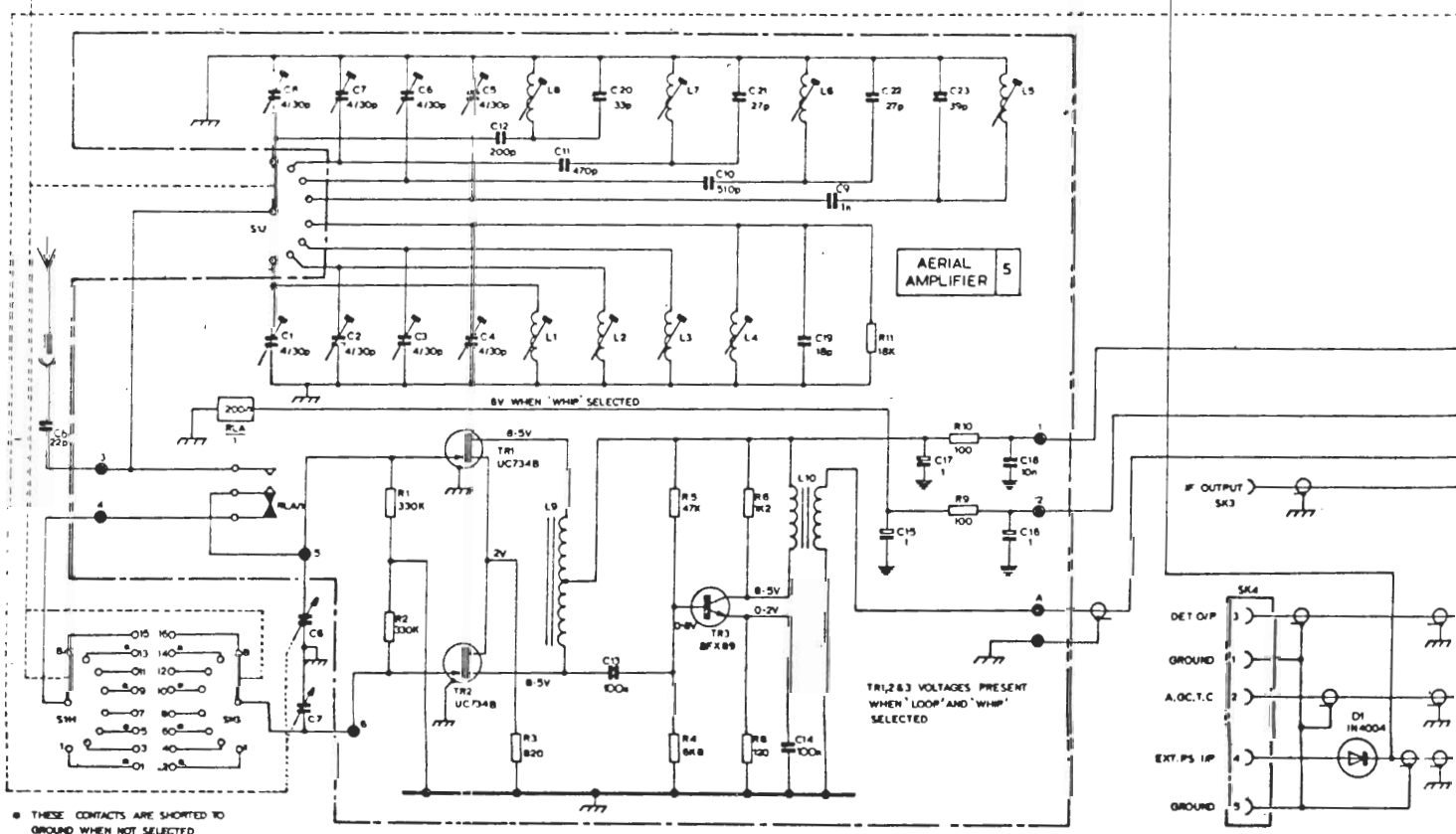
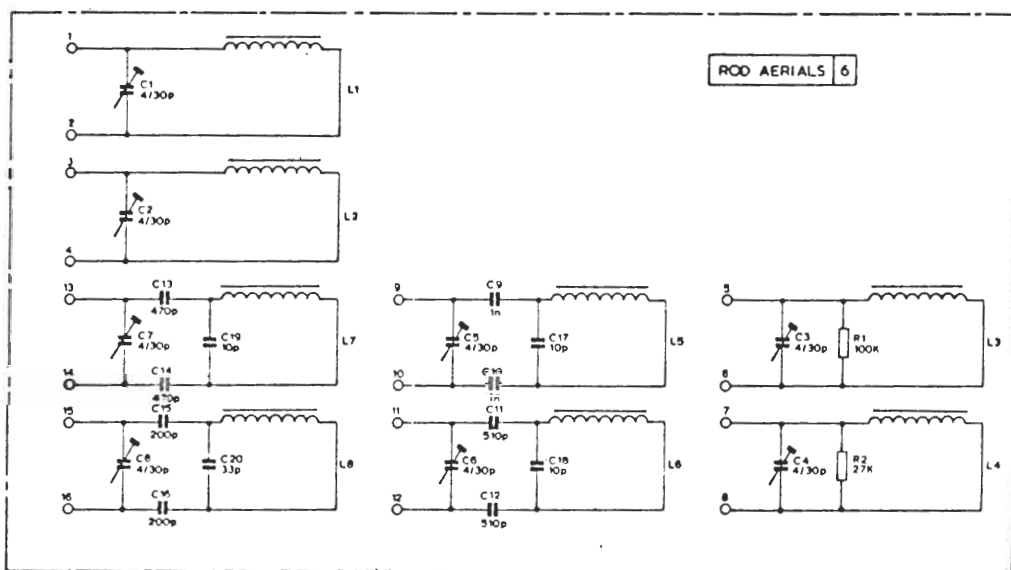
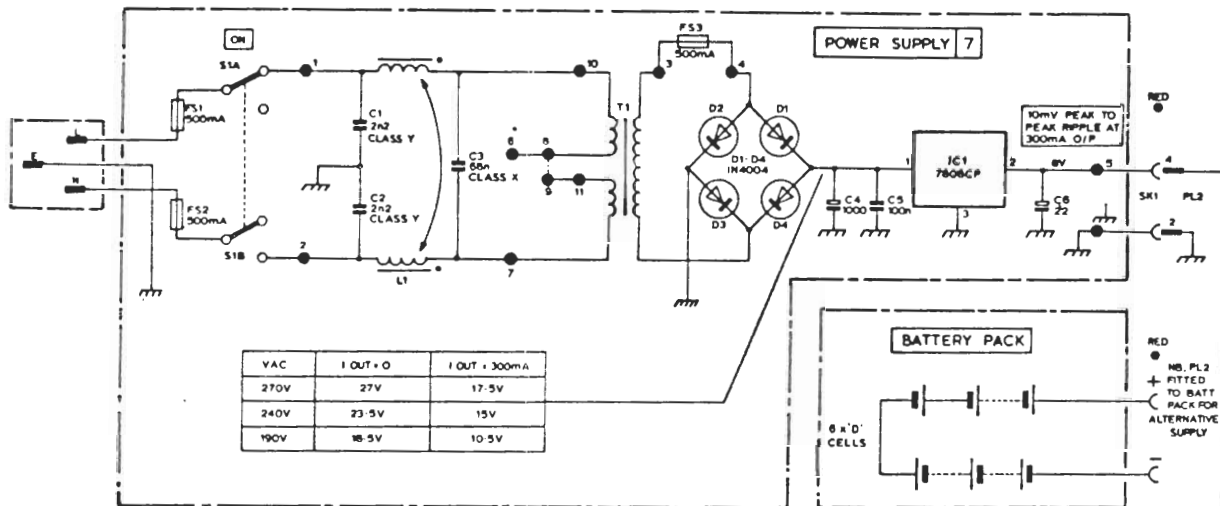

MAIN IF BOARD 3

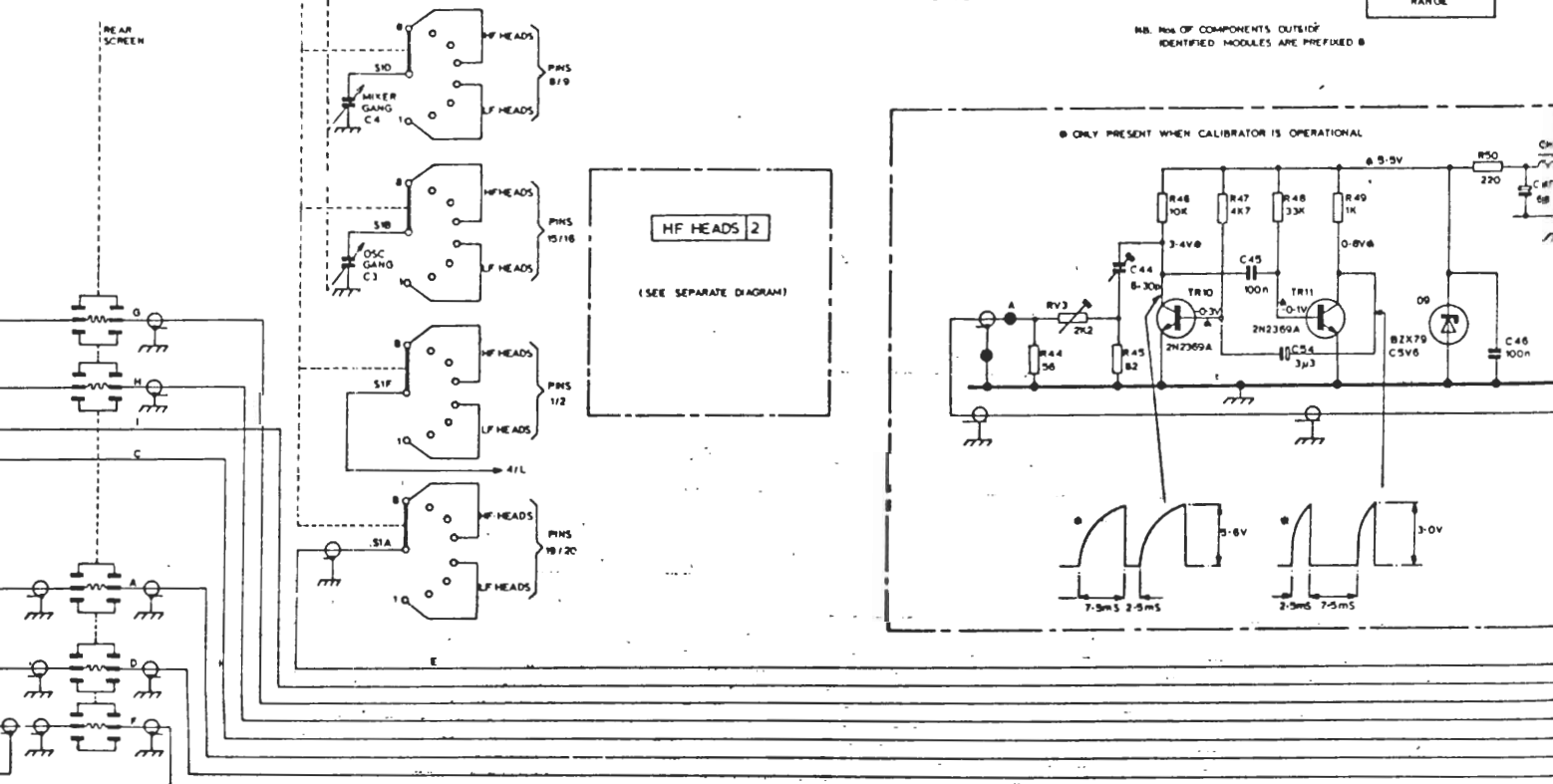
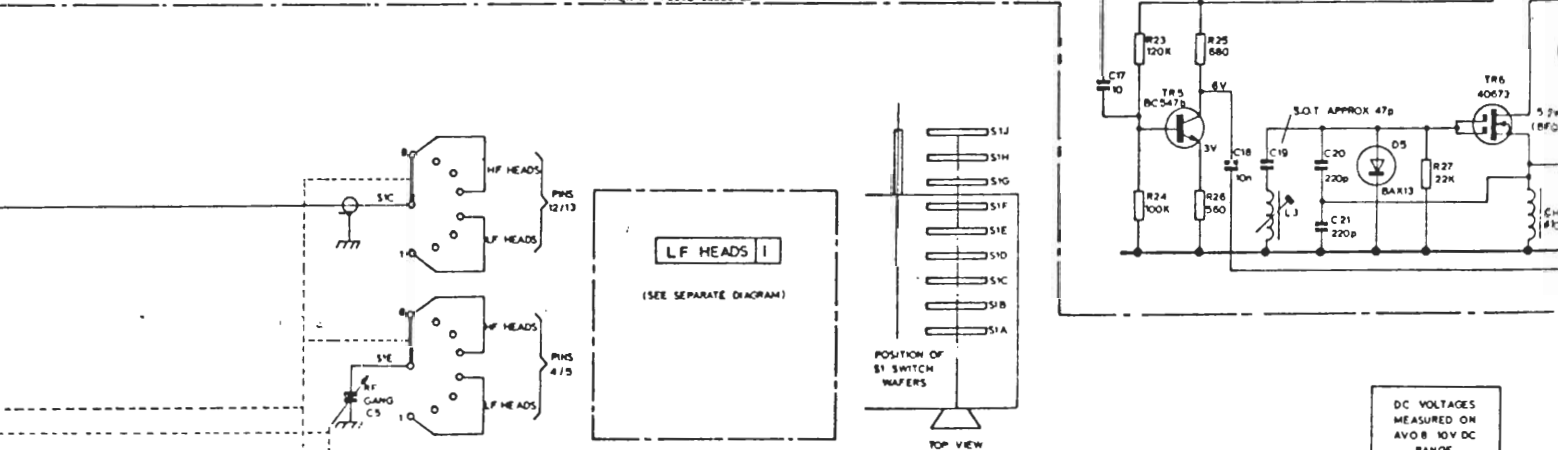
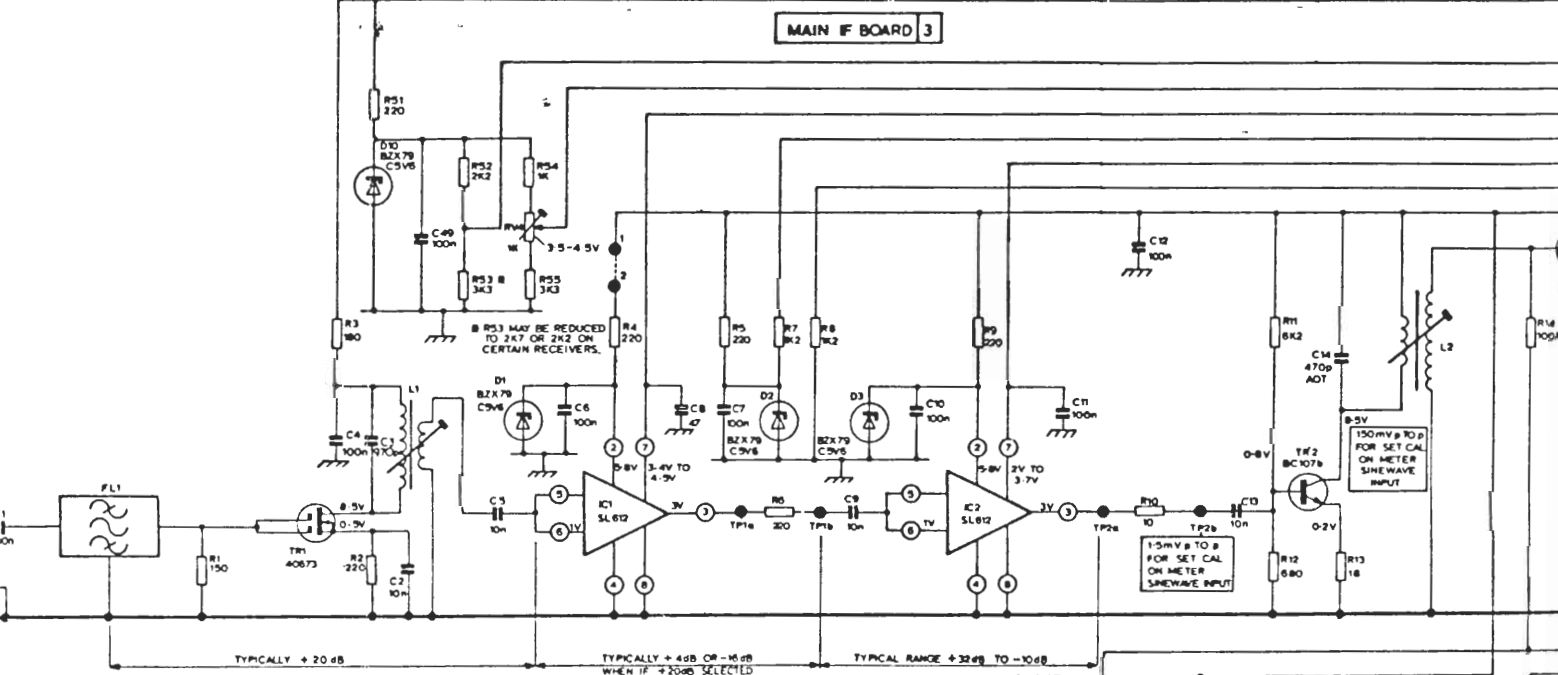

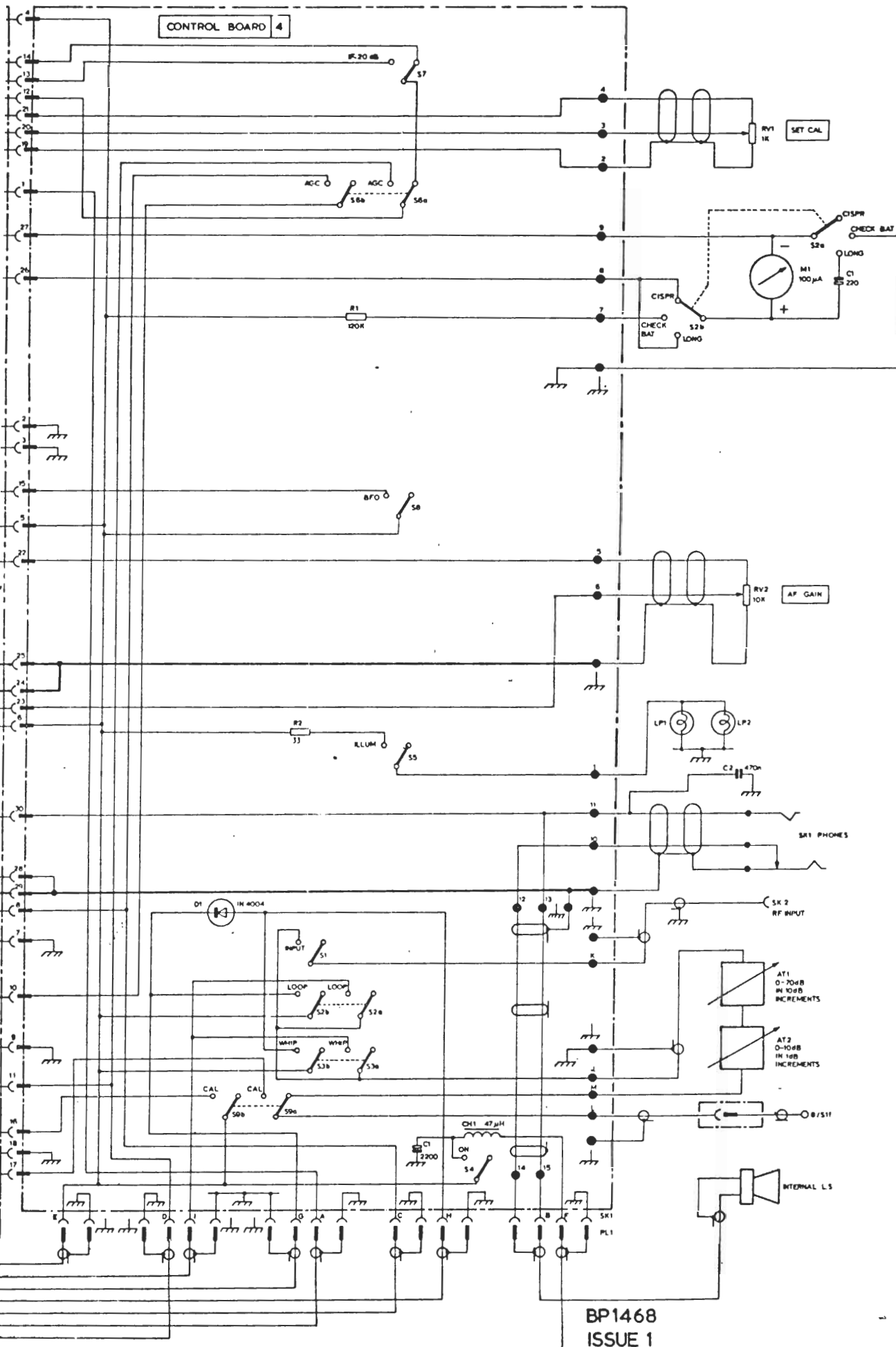

BP1468
ISSUE 1